



Hybrid Rear Axle Module (HRAM)

Features

- Hydraulic module for actuations
- Single-speed or 2-speed
- eLSD differential (modularity with open diff, MLSD)
- EM coaxial to half shafts

Benefits

- Additional electric power in combination with a high-efficiency mechanical layout
- Highly integrated design
- No modifications needed on the ICE and gearbox
- Battery boost characteristics

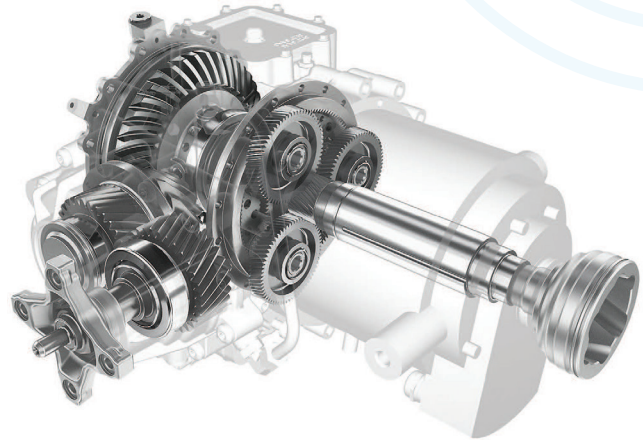

Ideal for high-performance sports car applications.



Hybrid Rear Axle Module (HRAM)

The Graziano™ hybrid rear axle module (HRAM) is available as a single-speed or two-speed variant. It's designed specifically for high-performance hybrid rear wheel and four-wheel drive vehicles. The HRAM features an electronic limited-slip differential (eLSD), hydraulic actuators, and an electric motor with a hollow rotor.

Vehicle	High-performance hybrid 4WD
Driveline Layout	Rear-wheel drive, coaxial electric motor
Product	<ul style="list-style-type: none"> ■ Hybrid rear axle module single-speed or 2-speed variant (ratios, torque, and power ranges flexibility with open diff, MLSD, eLSD modularity matching various applications) ■ P3 and P4 modularity
Motor Features	176 kW, max. speed 15,000 rpm, max. torque 293 Nm
Ratios	<p>E-mode: Single-speed $i = 6,467$ 2-Speed $i_1 = 11,9$ $i_2 = 4,58$</p> <p>ICE mode: from 2,44 to 3,7</p>
Gearbox Features	<ul style="list-style-type: none"> ■ Hybrid functionality for this fully integrated system is provided by an electric motor with a hollow rotor which allows one of the half shafts to pass through it. ■ The electric motor is connected via a transmission ratio (2-speed variant available for a higher torque speed envelope and better efficiency) realized via a planetary gear set to the differential housing. ■ The HRAM comprises a modular hydraulic power-pack for controlling the eLSD and the 2-speed device if needed.
Future Developments	Variant with torque vectoring system under development

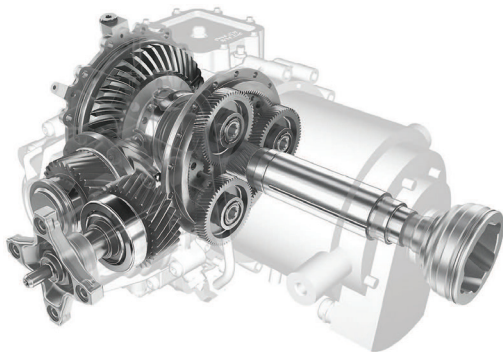

Dana.com

Application Policy

Capacity ratings, features, and specifications vary depending upon the model and type of service. Application approvals must be obtained from SME; contact your representative for application approval. We reserve the right to change or modify our product specifications, configurations, or dimensions at any time without notice.

