



# A BETTER WAY

SUSTAINABILITY AND SOCIAL RESPONSIBILITY REPORT 2020



Dana World Headquarters, Maumee, Ohio, United States

## About Us

Message From the Chairman and CEO	1
Fast Facts	3

## People

Safety First	8
Inclusion and Diversity	16
People Development	24
Health and Well-being	27
Growing Stronger, Together	28

## Products

Quality Focused	32
Global Technology Centers	38
Electrification. Delivered.™	41
Sustainable Supply Chain	47

## Planet

Environmental Stewardship	51
Tackling Climate Change	52
Thinking Big	53
Community Engagement	64

## Governance

Corporate Culture Matters	72
Standards of Business Conduct	74
Stakeholders	76
Dana Leadership	80

## Appendix

Methodology	83
GRI Index	85



# Dear Fellow Stakeholders,

I am pleased to share with you Dana's 2020 Sustainability and Social Responsibility Report. At Dana, corporate social responsibility encapsulates our vision for a better future, adopting a balanced approach that considers the people we encounter, the products we develop, and the planet that enables us to do our work.

Our world is a remarkable place worth fighting for, and we all have a responsibility to protect a shared planet that intersects every aspect of our lives. Within the mobility industry, we have a unique opportunity to lead by example, not only in how we

*“YOU HAVE TO DECIDE  
WHAT KIND OF  
DIFFERENCE YOU  
WANT TO MAKE.”*

design and develop products, but in how we manufacture them to reduce our impact on the environment.

As an organization, we recognize the need to embrace technology and reimagine how we do things to ensure

that present and future generations have a prosperous and sustainable place to live.

I agree with the principle that what you do makes a difference, and that you have to decide what kind of difference you want to make. In 2020, Dana committed to reducing our total annual greenhouse gas emissions by more than 50 percent before the end of 2035. We also signed a long-term renewable energy

agreement that will reduce our current U.S. annual greenhouse gas emissions from electricity by approximately 90 percent.

We continued adding solar power generation to Dana manufacturing facilities and we expanded our use of advanced energy-efficient production processes around the world to reduce our greenhouse gas emissions, water consumption, and waste. We also report annually to the Carbon Disclosure Project, an international non-profit organization, to ensure transparency of climate change management for all stakeholders.

Furthermore, we appointed our first Chief Sustainability Officer and added a standing Technology and Sustainability Committee to our Board of Directors to access their strategic insight relating to innovation, new technologies, and sustainability and social responsibility.

## **Electrification. Delivered.™**

Working out the best ways to tackle climate change is one of the key challenges facing policymakers and manufacturers.

Through our electrified product portfolio, we are acting now to support vehicle electrification and other sustainability initiatives to help achieve the Paris Climate Agreement targets that we have supported. In fact, our range of technologies delivers efficiencies across traditional powertrains, hybrids, electrics, and even hydrogen fuel-cells.



*“OUR RANGE OF TECHNOLOGIES IS ABLE TO DELIVER EFFICIENCIES ACROSS TRADITIONAL POWERTRAINS, HYBRIDS, ELECTRICS, AND EVEN HYDROGEN FUEL CELLS.”*

We remain steadfast in our efforts to contribute to the global economy by creating innovative technologies and products. These new competencies further enhance our ability to deliver all elements of a complete, fully integrated electrified system across all mobility markets in any region of the world. Our network of global technology centers is home to hundreds of the world’s leading engineers, technicians, and scientists and is strategically located across nine countries to ensure proximity to customers.

In 2020, we developed e-Propulsion systems (e-Axles, e-Drive units, e-Hub drives, e-Gearboxes), e-Motion systems, complete fully integrated e-Powertrains, and electrodynamic modules. This includes co-innovating with our partners to shape the next generation of mobility technology and anticipating every step of the innovation journey through advanced engineering and product development.

### Higher Purpose

From Brazil to Belgium and Canada to China, Dana’s higher purpose is lived by 38,000 employees located in 33 countries working toward a better tomorrow for our customers and communities.

Safety is our No. 1 priority, and we continuously strive to foster a culture where all ideas are welcomed, and our employees always feel safe and empowered. Global recognition during 2020 as one of the World’s Best Employers by *Forbes* and one of the Most Responsible Companies by *Newsweek* is a testament to how strongly we live these values.

This has been a year unlike any other in my lifetime. I felt the power of the Dana family and the depth of our team’s character as we managed through the operational challenges of the pandemic with more than 100 major facilities around the world temporarily idled to slow the spread.

I saw how our people applied their expertise to manufacture critical components for ventilators and source millions of masks, gloves, face shields, and thermal body scanners for our front-line workers and community partners. Our spirit of "One Dana" and a duty of care for each other sparked innovation, collaboration, and resilience which I know can be applied to future global challenges.

This mindset of resiliency underscores everything we do at Dana. It embraces our commitment to living a higher purpose; helping customers innovate and achieve their goals; focusing on total systems thinking; serving our communities; and creating more sustainable practices that strengthen our business in a changing world. We are [People Finding A Better Way](#).

My personal best,

James K. Kamsickas  
Chairman and Chief Executive Officer



*“GLOBAL RECOGNITION DURING 2020 AS ONE OF THE WORLD’S BEST EMPLOYERS IS A TESTAMENT TO HOW STRONGLY WE LIVE THESE VALUES.”*

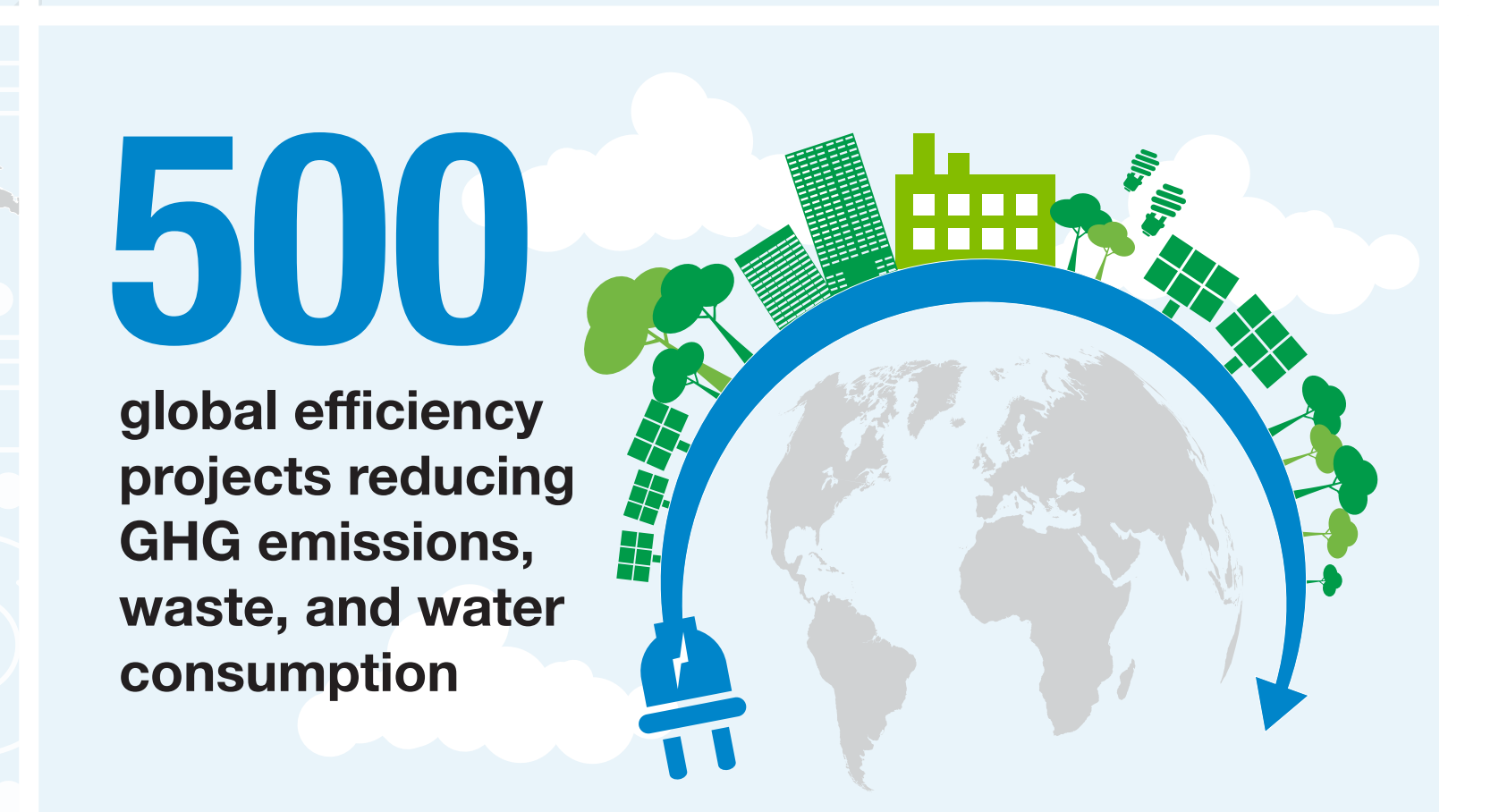
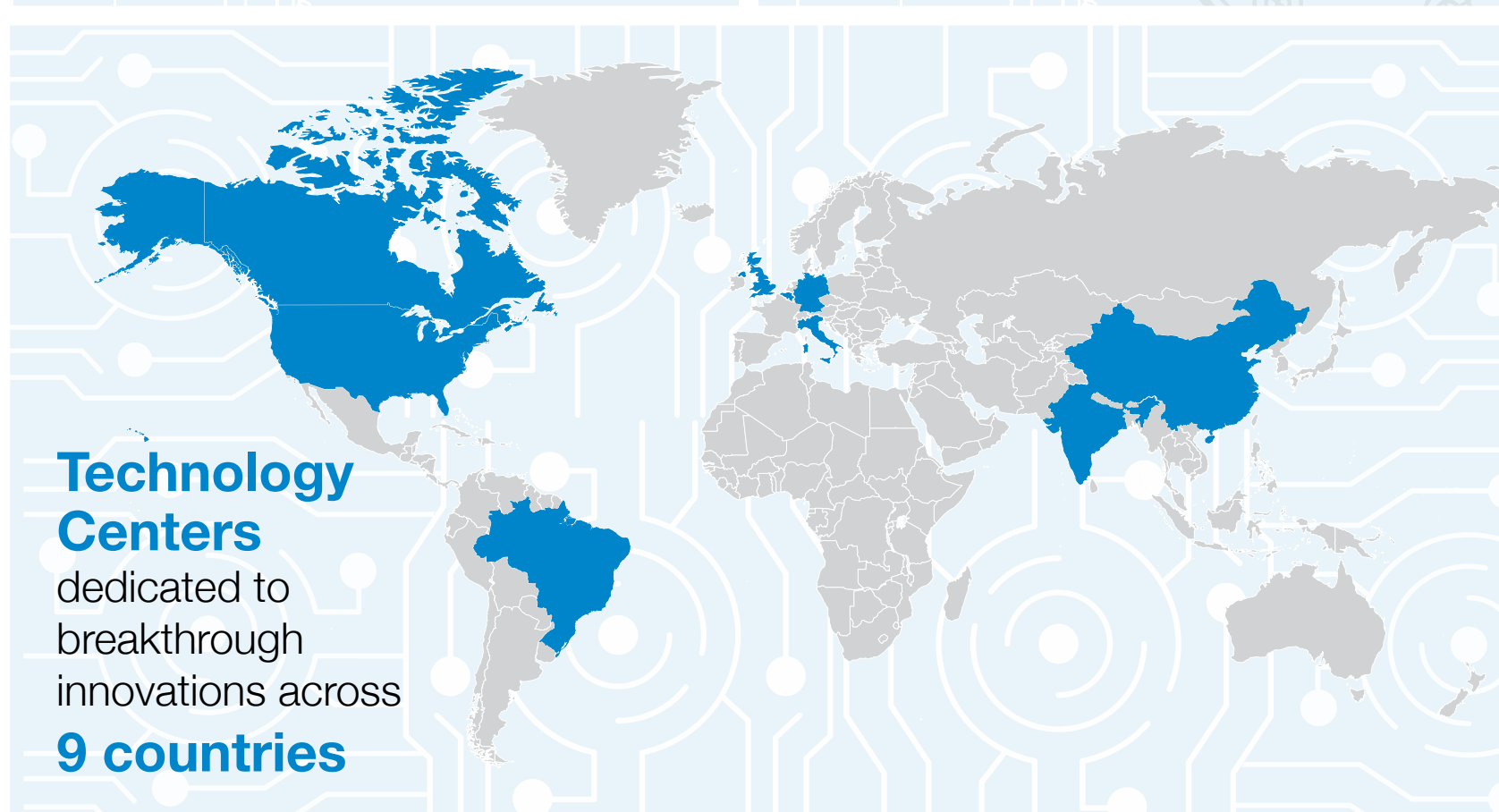
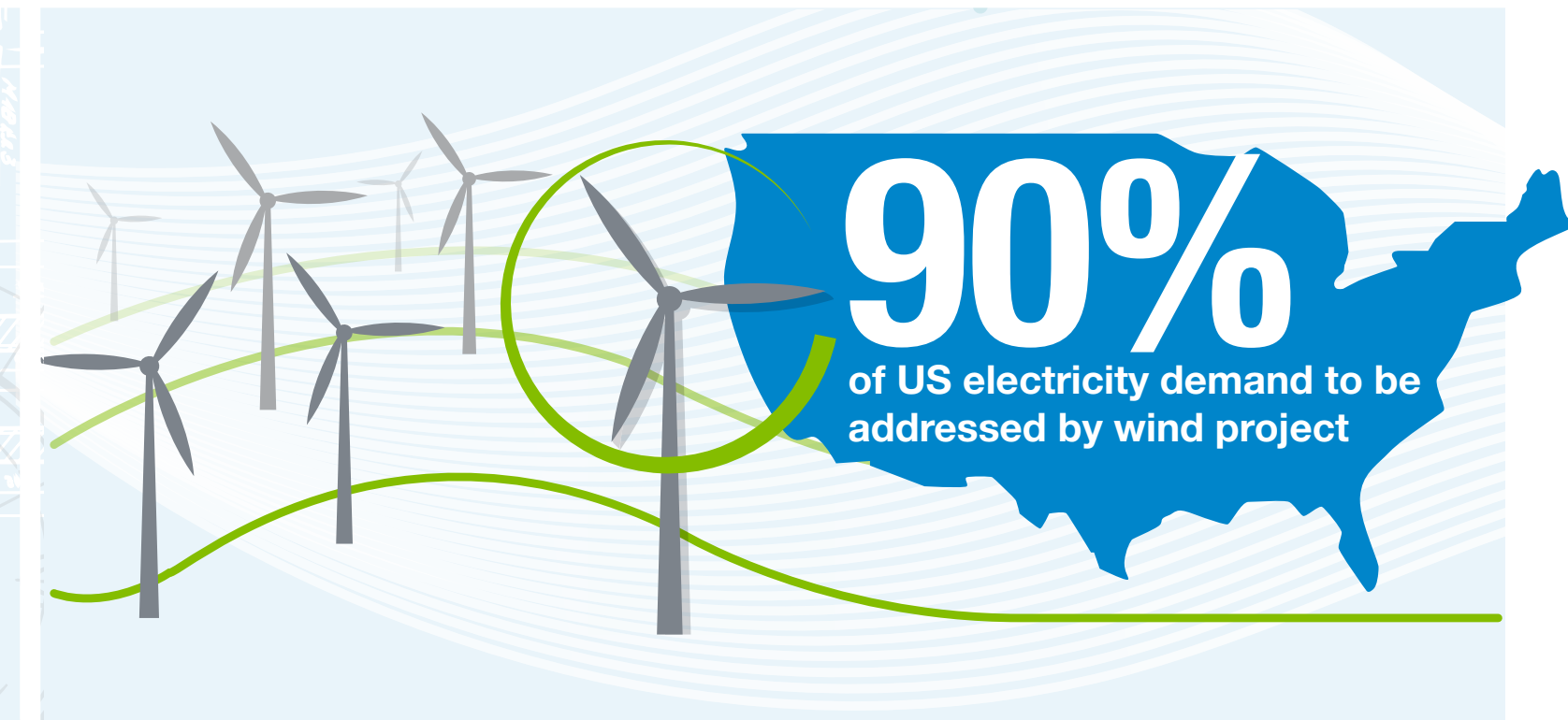
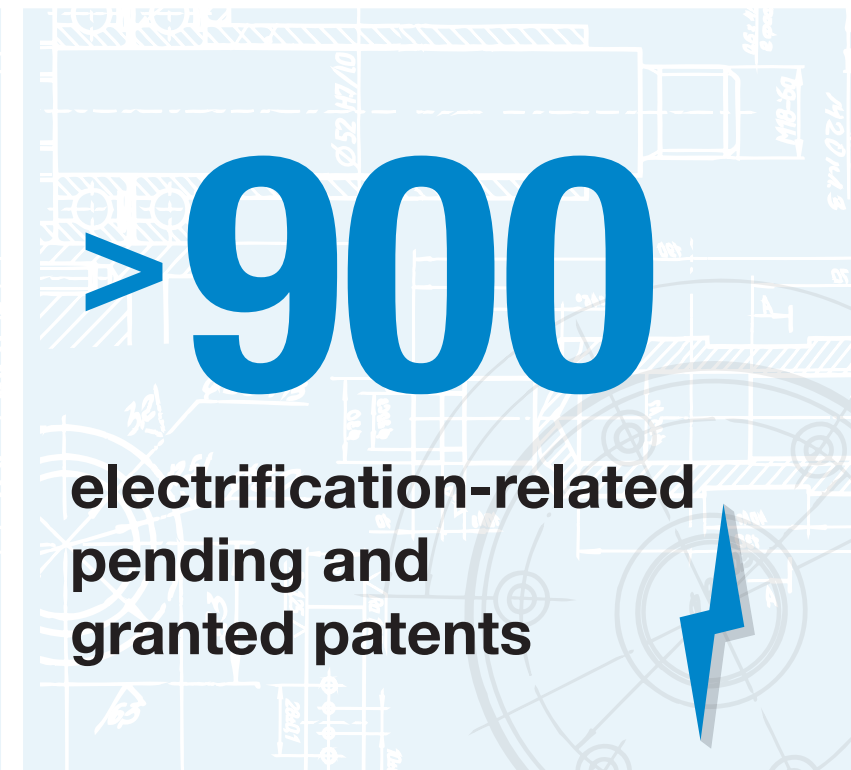
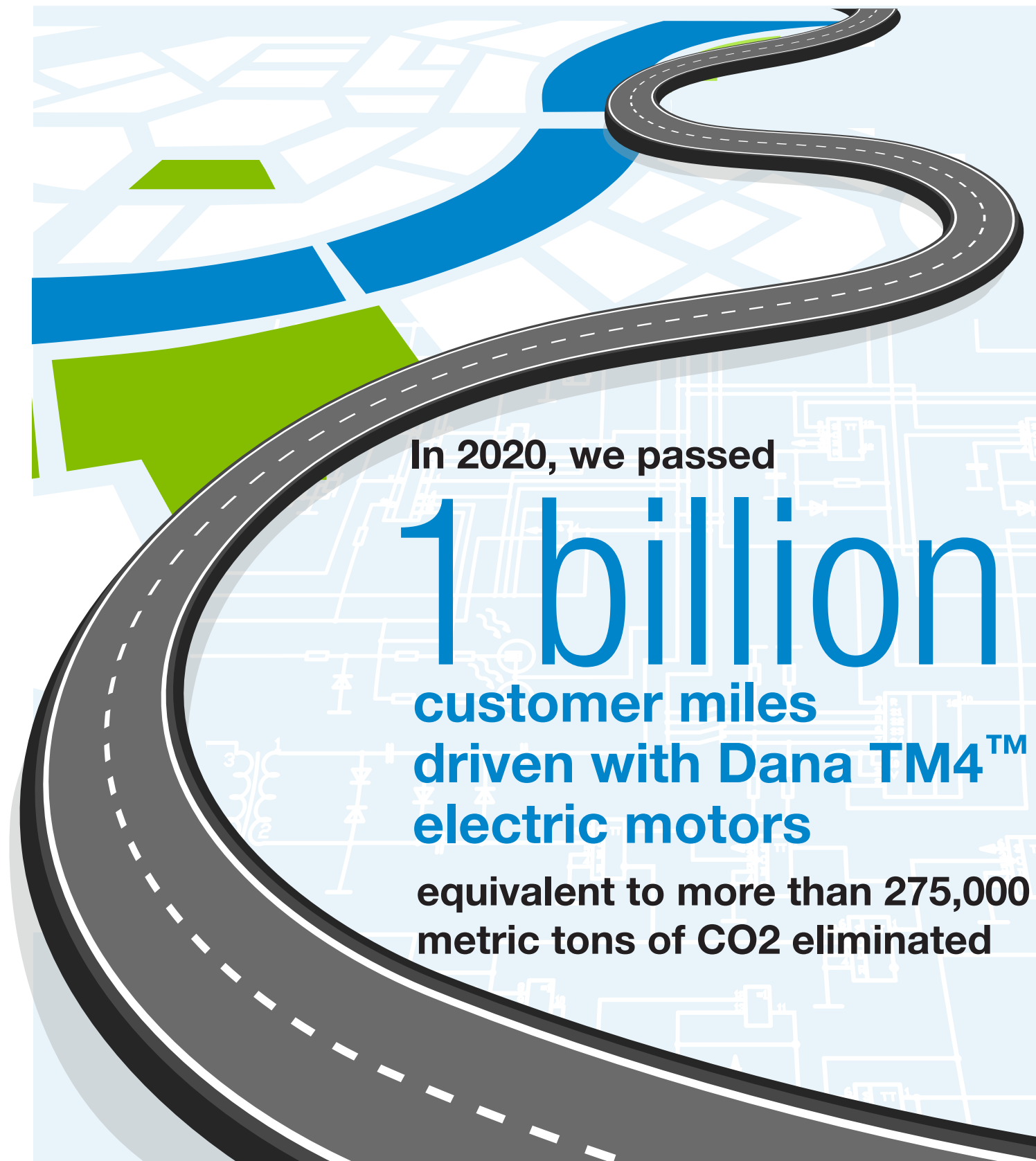
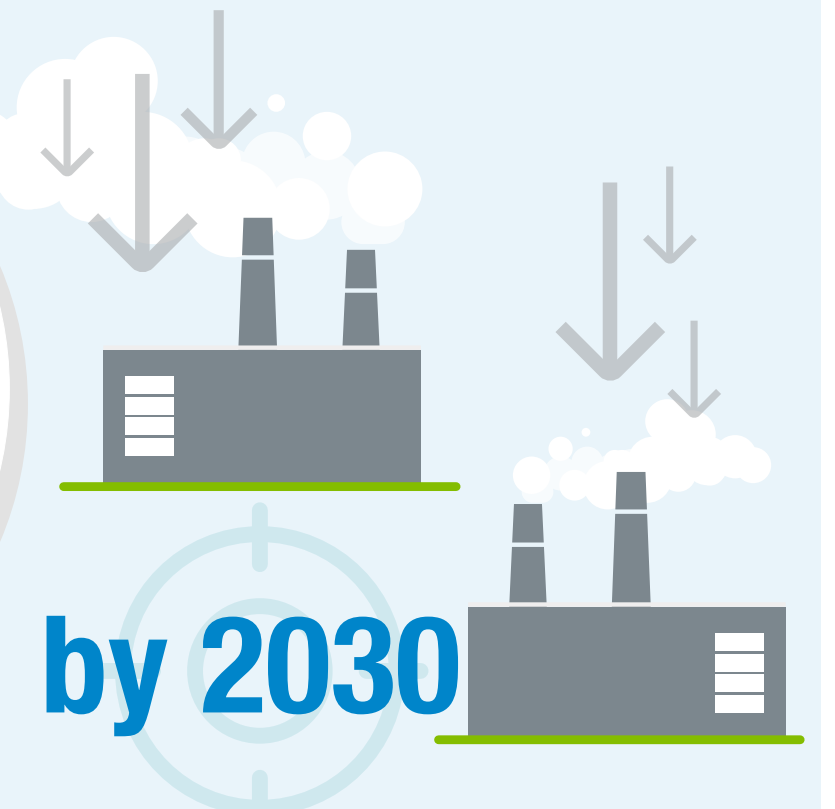
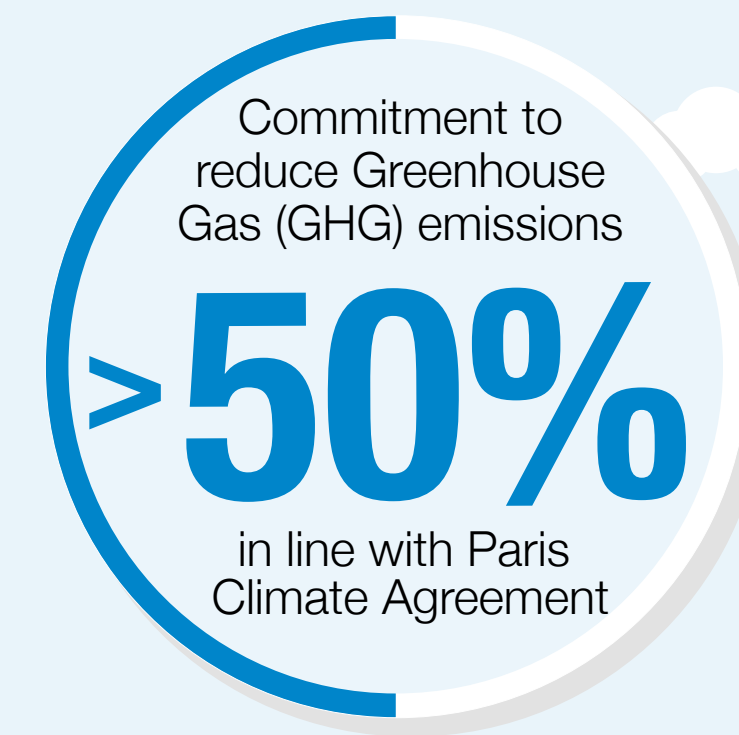



Established in **1904**. Employing **38,000** people across **141** major facilities in **33** countries. Shipping to **14,000** customers in **141** countries. Leveraging a global network of technology centers across **9** countries.

## Vision

To be the global technology leader in efficient power conveyance and energy-management solutions that enable our customers to achieve their sustainability objectives.

## Mission

Our talented people power a customer-centric organization that is continuously improving the performance and efficiency of vehicles and machines around the globe. We will consistently deliver superior products and services to our customers and will generate exceptional value for our shareholders.

**This mission is embodied in our company theme:**

*People Finding A Better Way®*

## Values

Honesty and Integrity  
Good Corporate Citizenship  
Open Communication  
Continuous Improvement

# Sales Snapshot

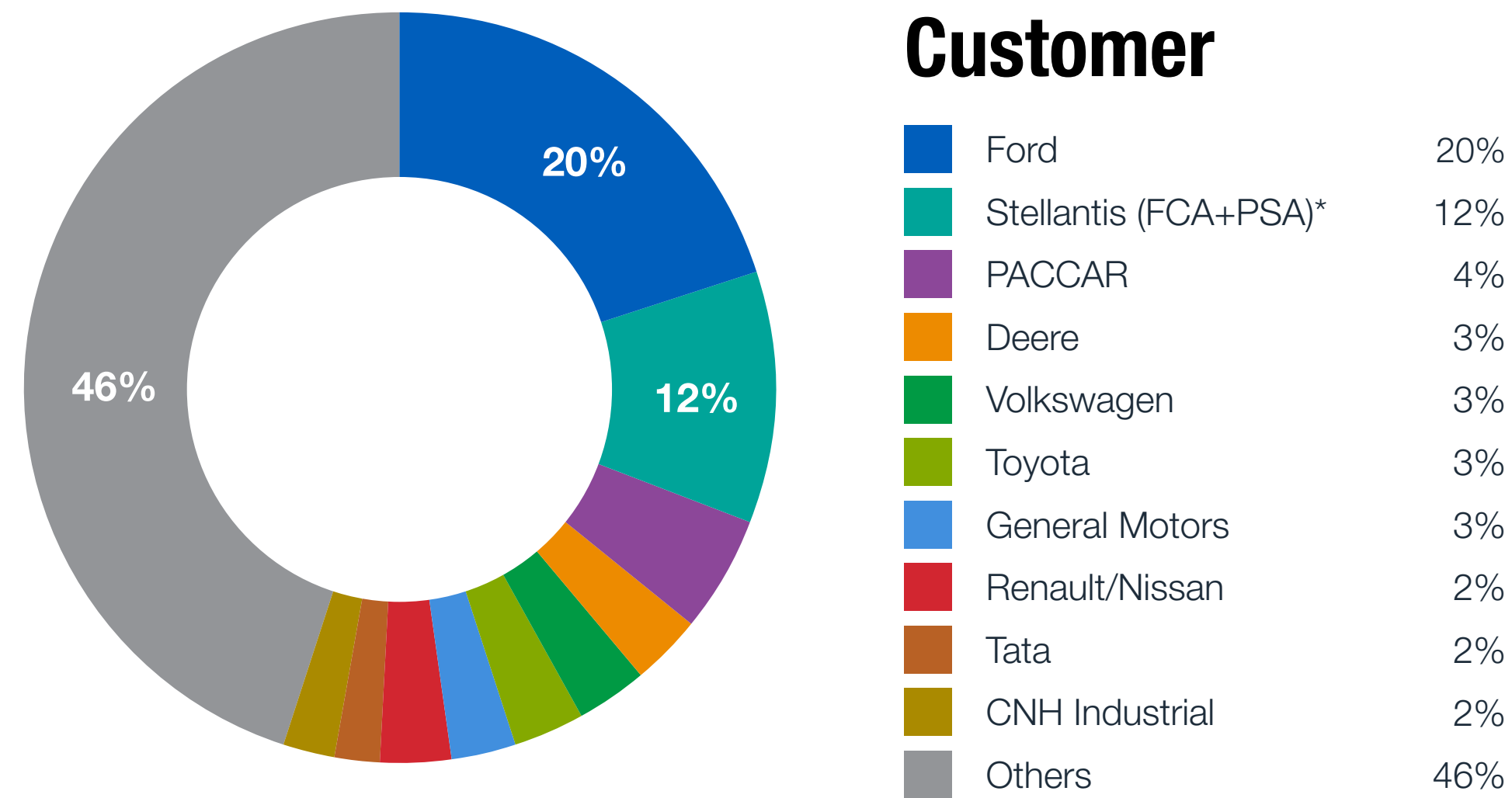

\*Includes sales to system integrators for driveline products that support Stellantis vehicles.

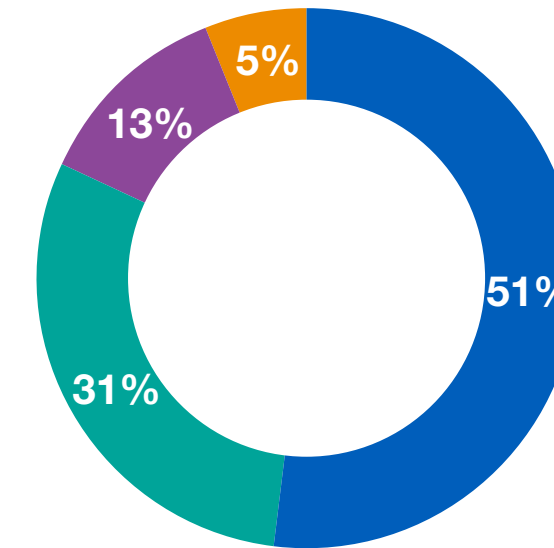

## Region

North America	51%
Europe	31%
Asia Pacific	13%
South America	5%

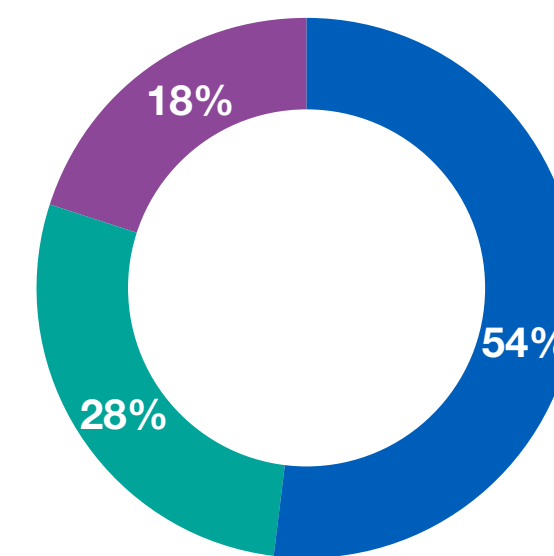

## Market

Light Vehicle	54%
Off-Highway	28%
Commercial Vehicle	18%

## Segment

Light Vehicle	43%
Off-Highway	28%
Commercial Vehicle	16%
Power Technologies	14%

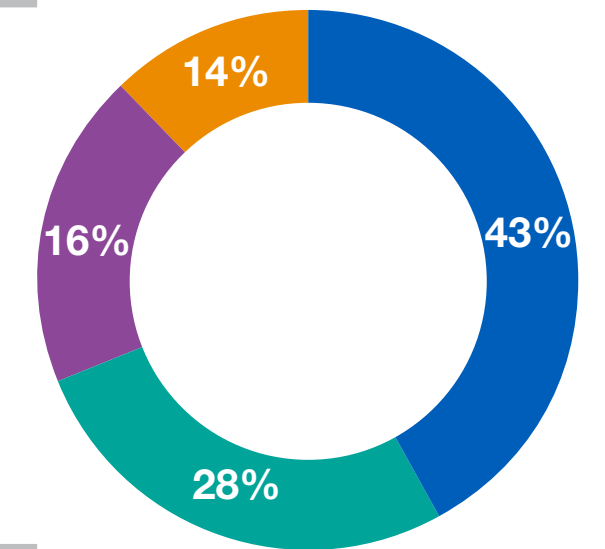

All figures as of year-end December 31, 2020.

# Business Units

## Light Vehicle Drive Systems

Dana is a leading supplier of fully integrated drivetrain and electrified propulsion systems for all passenger vehicles. Working collaboratively with original-equipment manufacturers and the aftermarket, we focus on delivering best-in-class efficiency, maximum durability, and superior ride and handling across the globe.

## Commercial Vehicle Drive and Motion Systems

Dana is an industry leader in the supply of traditional and electrified systems for medium- and heavy-duty commercial vehicles. We help original-equipment manufacturers and end-market customers achieve the best weight, performance, and efficiency, as well as the lowest cost of ownership, no matter the powertrain configuration.

## Off-Highway Drive and Motion Systems

Dana delivers mobile drivetrain and motion solutions for construction, agriculture, material handling, and mining equipment, as well as motion systems for a wide variety of mobile and stationary industrial applications. These customized solutions support vehicles and machines with both conventional and electrified power sources and are designed to deliver innovative technologies that meet customer demands and goals worldwide.

## Power Technologies

Dana provides advanced sealing and thermal-management solutions to all end markets in support of both conventional and electrified platforms. Leveraging the most cutting-edge technology and manufacturing processes, we deliver custom-engineered solutions designed to optimize vehicle efficiency and performance.







# PEOPLE

# What Safety First Means at Dana

We believe that Dana has an essential accountability to safeguard life, health, property, and the environment for the well-being of everyone. This is achieved through a consistent commitment to excellence in safety, health, and security management through the prevention and elimination of hazards.

At Dana, we care deeply about the health and safety of one another — employees, customers, suppliers, visitors, contractors, and the community. Through effective feedback and positive recognition, we actively promote and pursue safety in all that we do. Our “Safety First” approach requires a daily, focused effort.

## OUR COMMITMENT TO SAFETY

All successful safety programs start with leadership commitment with clarity on roles and responsibilities throughout the organization. Dana’s approach to health and safety focuses on people, culture, performance, and results. Behavior is key to each of these elements — whether it’s management, team, or individual behaviors.

The role played by leadership provides a critical link to ensure the effective development, modification, and implementation of safety processes. Nevertheless, Dana’s safety and health program requires all employees to take an active role in leading, guiding, and assisting safety awareness, hazard control, and loss prevention.

*"A SAFE WORK ENVIRONMENT IS DRIVEN BY A CULTURAL MINDSET."*

**SafetyFirst**  
All Day Every Day



## EXCELLENCE IN HEALTH AND SAFETY MANAGEMENT SYSTEM CERTIFICATION

The benefits of a formalized Safety Management System (SMS) are considerable when implemented by organizations that are serious about improving employee safety, reducing workplace risks, and creating better, safer working conditions.

In 2017, Dana's leadership team committed to getting Dana manufacturing facilities registered to the world's first international occupational health and safety standard, International Organization for Standardization (ISO) 45001. As of December 31, 2020, 78 total Dana manufacturing sites (75%) were SMS certified.

This ISO certification establishes the requirements of an effective occupational health and safety management system that can be integrated with other management requirements and help to achieve our strict health and safety objectives.

The ISO certification process facilitates internal improvements and provides third-party validation that Dana is focused on the most important piece of our sustainability and social responsibility program — our people.

We plan to certify all manufacturing facilities by 2022 and remain committed to an implemented, verified, audited, and communicated occupational health and safety management system.



*"IN 2020, AN ADDITIONAL 27 DANA MANUFACTURING FACILITIES BECAME SAFETY MANAGEMENT SYSTEM CERTIFIED."*





# SAFETY DATA

### Recordable Incident Rate

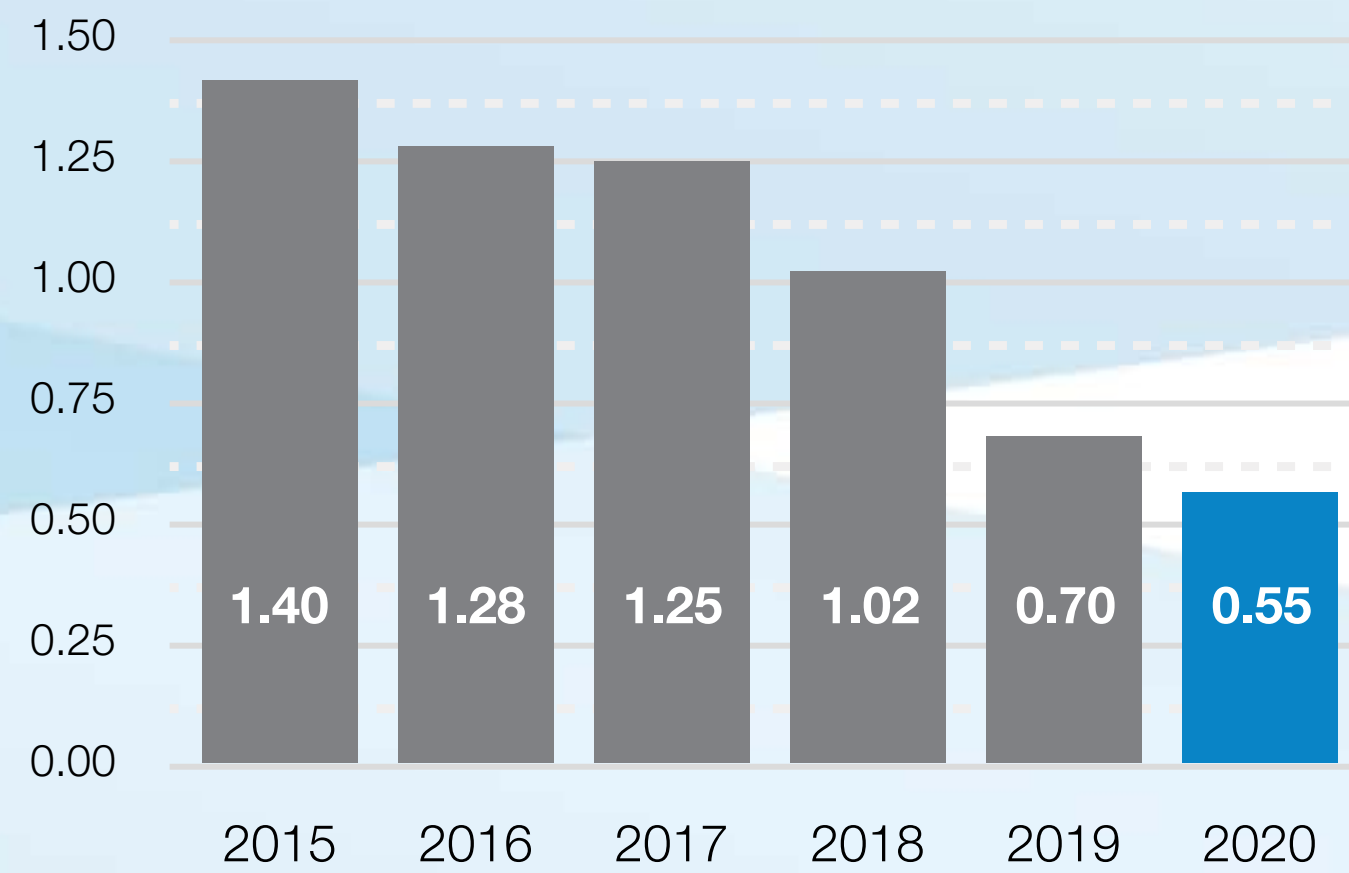

### Lost Time Recordable Incident Rate

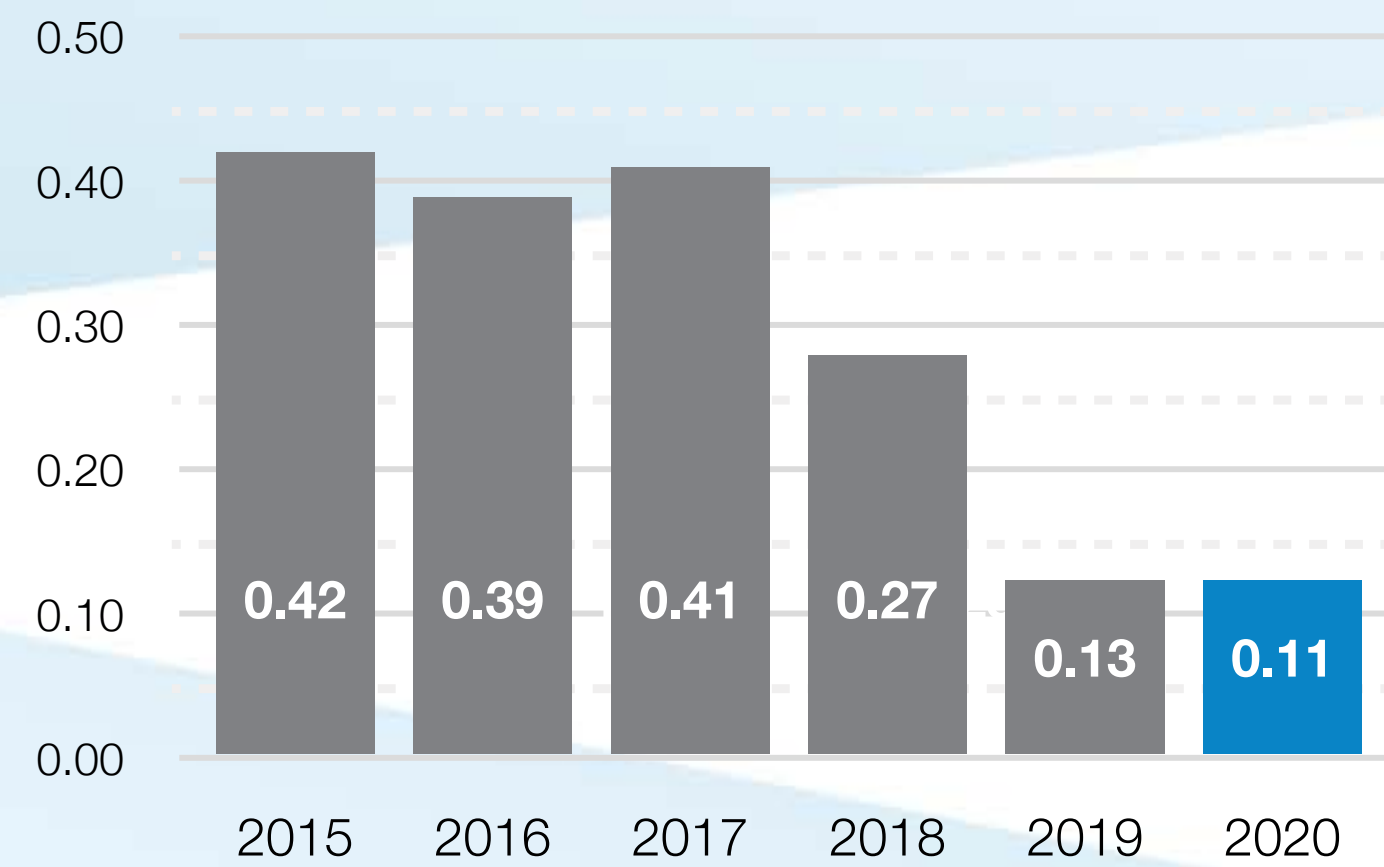

### Facilities with No Lost Time Incidents (%)

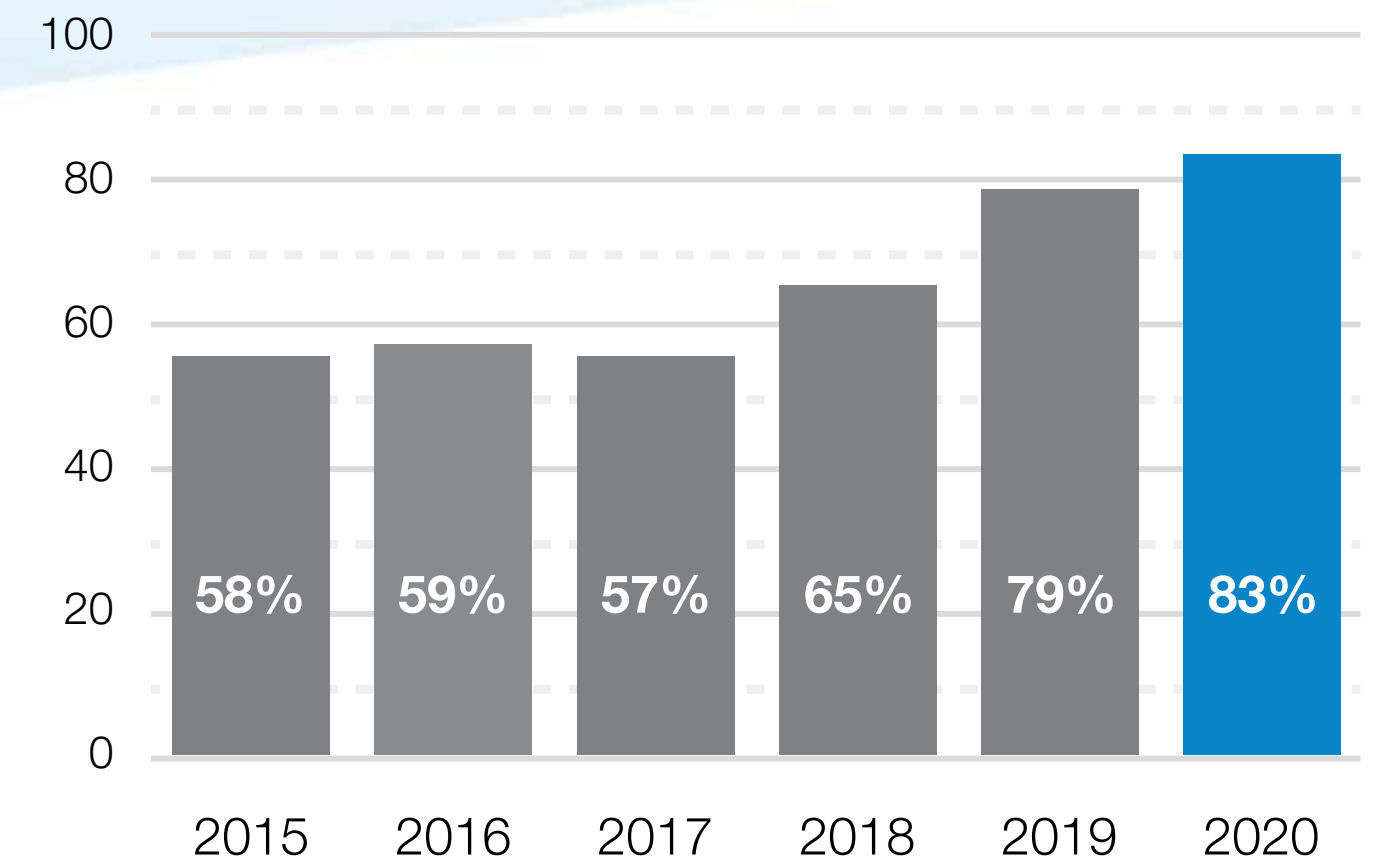

## FACILITIES REACHING 1 MILLION+ HOURS WITHOUT A LOST-TIME INCIDENT IN 2020: NORTH AND SOUTH AMERICA

In 2020, 31 of our plants in North and South America achieved significant milestones for working safely.

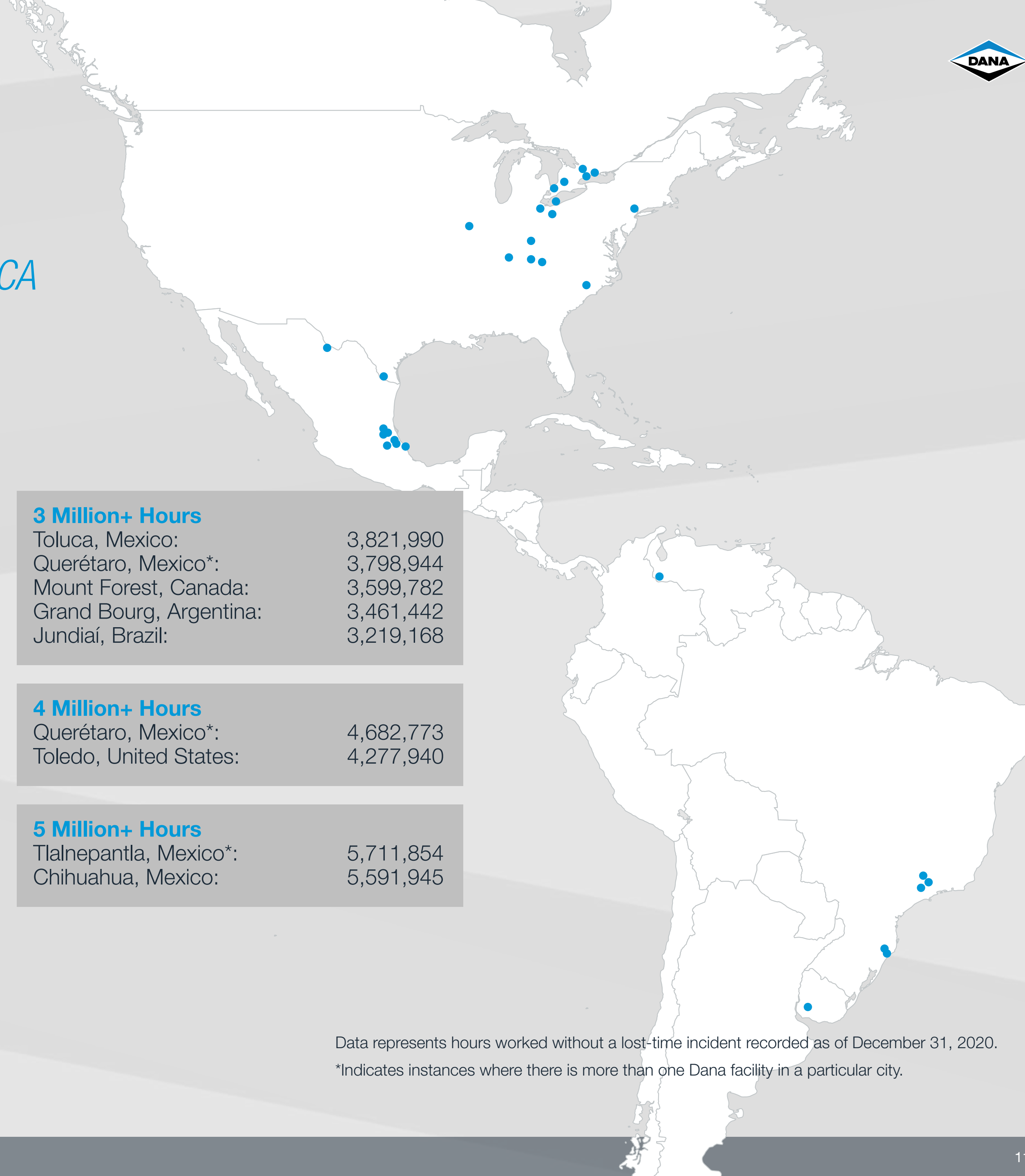

### 1 Million+ Hours

Columbia, United States:	1,825,117
St. Clair, United States:	1,707,430
Gravataí, Brazil*:	1,665,321
Sorocaba, Brazil:	1,516,424
Tlaxcala, Mexico:	1,305,098
Gordonsville, United States:	1,300,880
Crossville, United States:	1,276,364
Cambridge, Canada:	1,265,659
Campinas, Brazil:	1,174,003
Lugoff, United States:	1,098,423
Oakville, Canada:	1,057,051
Gravataí, Brazil*:	1,037,108
Bucaramanga, Colombia:	1,012,915

### 2 Million+ Hours

Louisville, United States:	2,888,103
Monterrey, Mexico:	2,808,724
Pottstown, United States:	2,676,562
Querétaro, Mexico*:	2,581,830
Tlalnepantla, Mexico*:	2,540,170
Auburn Hills, United States:	2,512,995
Paris, United States:	2,286,153
Fort Wayne, United States:	2,245,667
Lima, United States:	2,015,115

### 3 Million+ Hours

Toluca, Mexico:	3,821,990
Querétaro, Mexico*:	3,798,944
Mount Forest, Canada:	3,599,782
Grand Bourg, Argentina:	3,461,442
Jundiaí, Brazil:	3,219,168

### 4 Million+ Hours

Querétaro, Mexico*:	4,682,773
Toledo, United States:	4,277,940

### 5 Million+ Hours

Tlalnepantla, Mexico*:	5,711,854
Chihuahua, Mexico:	5,591,945

Data represents hours worked without a lost-time incident recorded as of December 31, 2020.

\*Indicates instances where there is more than one Dana facility in a particular city.



## FACILITIES REACHING 1 MILLION+ HOURS WITHOUT A LOST-TIME INCIDENT IN 2020: EUROPE AND ASIA

In 2020, 23 of our plants in Europe and Asia achieved significant milestones for working safely.

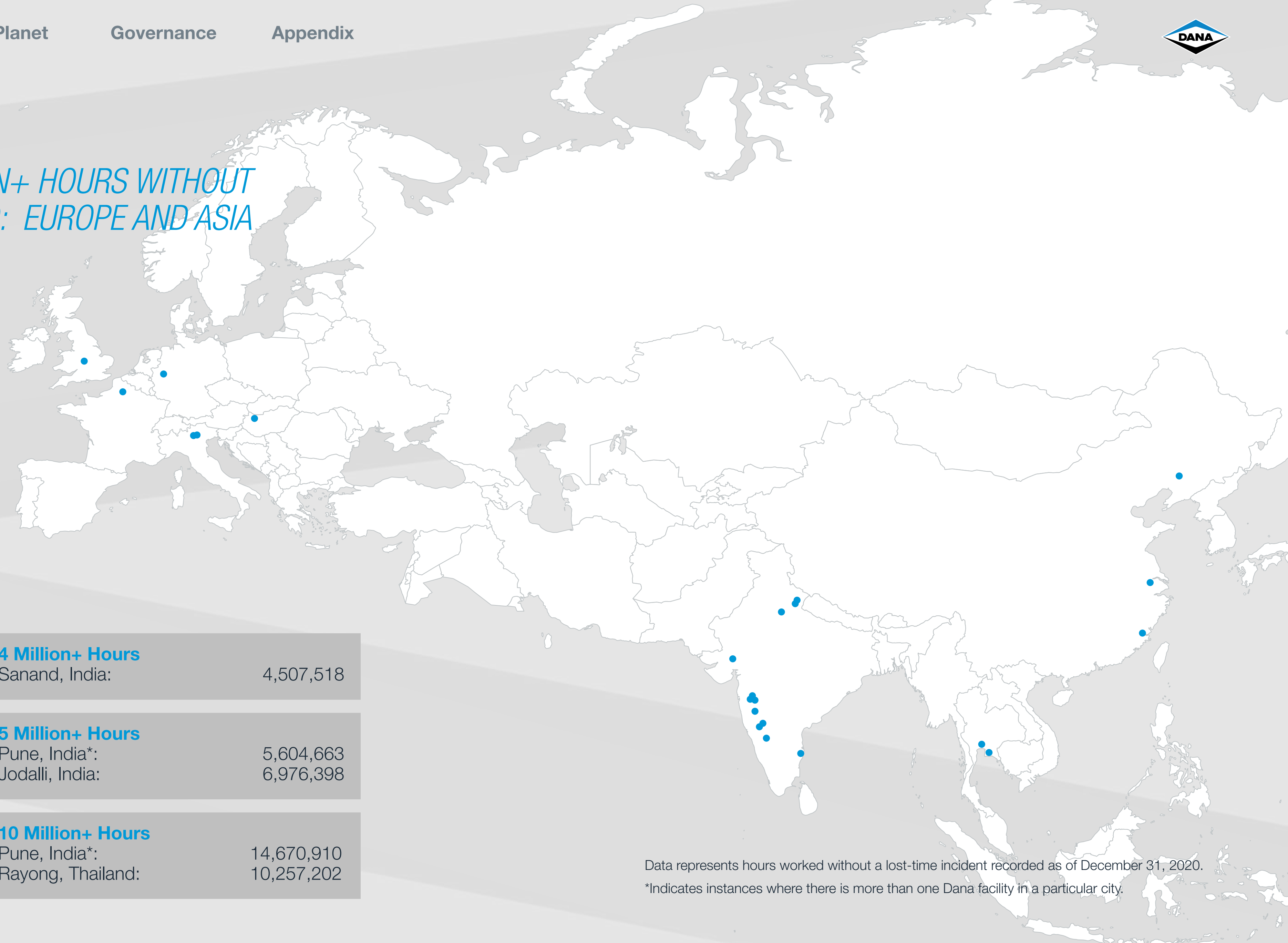

### 1 Million+ Hours

Belgaum, India*:	1,953,686
Birmingham, UK:	1,738,551
Pantnagar, India:	1,693,945
Essen, Germany:	1,444,086
Pune, India*:	1,414,950
Arco, Italy:	1,392,598
Guiscard, France:	1,307,401
Rovereto, Italy:	1,216,580
Rudrapur, India:	1,025,238

### 2 Million+ Hours

Wuxi, China:	2,703,775
Belgaum, India*:	2,558,395
Fuzhou, China:	2,357,188
Chennai, India:	2,318,083
Gyor, Hungary:	2,153,771

### 3 Million+ Hours

Shenyang, China:	3,796,112
Noida, India:	3,353,779
Bangkok, Thailand:	3,327,052
Satara, India:	3,304,763

### 4 Million+ Hours

Sanand, India:	4,507,518
----------------	-----------

### 5 Million+ Hours

Pune, India*:	5,604,663
Jodalli, India:	6,976,398

### 10 Million+ Hours

Pune, India*:	14,670,910
Rayong, Thailand:	10,257,202

Data represents hours worked without a lost-time incident recorded as of December 31, 2020.  
\*Indicates instances where there is more than one Dana facility in a particular city.

## CEO SAFETY AWARD 2020

*The CEO Safety Award goes to the facility that demonstrated the most outstanding safety performance over the past year.*

This year’s winner, Dana’s Power Technologies facility in Mount Forest, Ontario, Canada, has done an outstanding job making safety a top priority.

Their strong safety-first culture has created a highly engaged workforce where everyone views safety as a way of life and not just as a system or process. Since 2014, they have worked more than 3.6 million hours without a lost-time injury.

Safety is a shared responsibility at Mount Forest, which is achieved through a strong partnership among safety, operations, maintenance, engineering, the employee union and HR teams — who are genuinely committed to fostering a culture of safety in everything they do.

Together, they have built an innovative mindset that promotes a stop-and-fix mentality where everyone is quick to intervene, take a proactive approach, and implement best practices that engineer safety into every process throughout the plant.



Mount Forest plant, Ontario, Canada

### LaKesha Self

**Team Leader**  
Materials



“As the person in charge of verifying key components for axle construction, like rotors and calipers, you must be dynamic and decisive when scheduling and coordinating the development of new products.”

“I get to collaborate closely with so many talented people, including assembly technicians, the quality team, and material and assembly supervisors. So, I feel very much at the heart of things. I’ve learned through my role as a Union committee member and my participation on our Engagement Committee that Dana people are truly behind the product. There’s a genuine pride in our work and care for each other’s welfare.”

## SAFETY EDUCATION

*Essential to the success of an effective health and safety program is a fundamental level of safety awareness, as well as the knowledge and skills required for employees to do their work securely to avoid creating situations that could place themselves or others at risk.*

This requires an understanding of workplace risks and how to identify, report, and control them. This is why Dana makes a top priority and an integral part of all new employee orientation programs. Elements include:

- The employee's rights and responsibilities in the company's health and safety system.
- The importance of methods used to recognize, evaluate, and control workplace risks, including the prevention of unsafe conditions and unsafe acts.
- A thorough review of all applicable company safety rules, policies, and procedures; particularly Dana's Life Safety Rules, as well as those applicable to each work area.
- A full understanding of the importance of open communications in the health and safety management process.
- Any special risk information specific to the employee's work.

Additional qualification training is necessary on an on-going basis to help ensure that every employee is fully capable of performing all expected tasks in their work area in a safe and effective manner.

*"OUR SAFETY EDUCATION PROCESS BEGINS AT THE ONSET OF EMPLOYMENT AND CONTINUES THROUGHOUT AN EMPLOYEE'S TENURE WITH THE COMPANY."*





## MORE THAN 85,000 SAFETY CERTIFIED SUPERVISOR TRAINING PROGRAMS COMPLETED

Dana's Safety Certified Supervisor program provides a platform for all employees to advance through multiple tiers of safety training. During 2020, Dana employees successfully completed 85,076 safety training programs as part of this initiative.

Before undertaking certification training, employees first participate in Safety 101, featuring introductory modules on safety culture, safe behaviors, Dana's "Life Safety Rules," and safety resources.

Additional training more specifically addresses the safety challenges presented to employees, contractors, and / or visitors while on company property.

- Energy Isolation Lockout / Tagout
- Machine Safeguarding
- Fall Protection Work at Heights
- Powered Industrial Vehicles
- Electrical Safe Work Practices
- Confined Spaces
- Contractor Safety Management

### Stacy Schmidt

**Senior Manager**  
Safety Systems and Training



"Certainly 2020 brought many new and difficult challenges, but also many opportunities. For me, two in the safety realm stand out. For 28 of our facilities to achieve ISO 45001 certification — the international standard for occupational health and safety — is a significant accomplishment in the best of circumstances. In the midst of a global pandemic, it's nearly impossible."

"I was also impressed that our ongoing commitment to safety education and training around the world never wavered — reinforcing the 'safety IQ' of our workforce and our collective commitment to 'Safety First.'"



# What Inclusion and Diversity Means to Dana

At Dana, we focus on building teams that reflect real-world life experiences and we value curiosity and innovation from all of our 38,000 employees across 141 major facilities in 33 countries.

We believe that greater diversity in the workforce establishes a sense of belonging for everyone and creates a culture where every individual can contribute to their full potential. As well as being the right thing to do, it also results in increased profitability and value creation.

## Respectful and Inclusive

A mindset of inclusion and diversity reminds us that we all belong. Inclusion comes first because truly welcoming and valuing differences is what allows our diverse talent to feel confident and engaged.

We are committed to providing safe, respectful, and inclusive workplaces where everyone can contribute, participate, and thrive. A shared understanding of inclusion is what allows Dana colleagues — with their unique talents, perspectives, and preferences — to feel that they belong and that they matter.

While inclusion refers to the Dana behaviors that ensure people feel welcome, diversity refers to the qualities that make people unique. We respect and appreciate what makes colleagues different, including age, gender, ethnicity, religion, disability, sexual orientation, education, and national origin.

This means understanding one another and ensuring people truly value their differences, placing positive value on diversity in the global workforce and the community. For us, this is the who and the what. Who is being recruited, who is being promoted, and building a better world by incorporating everyone's characteristics is what is important.

Moreover, Dana champions seven Business Resource Groups (BRGs), which are voluntary, employee-led groups formed around shared identity, interests, and pursuits. Our BRGs represent and support the diverse communities that make up our workforce and are open to all employees.

Each BRG offers opportunities to network and connect with peers, participate in outreach programs, acquire new skills, and enhance leadership capabilities.

## INCLUSION AND DIVERSITY GOVERNANCE COMMITTEE

The Inclusion and Diversity Governance Committee aims to research, develop, and propose mechanisms and strategies to create a supportive, inclusive, and diverse workplace.

Partnering closely with Dana's Business Resources Groups, the committee supports and ensures alignment across multiple objectives.

- Assisting Dana leadership in the creation of diversity strategy, goals, and key milestones.
- Identifying and formulating recommendations for programs, policies, and work practices that affect recruitment and retention of a diverse workforce.
- Helping to design transparent processes to access to developmental and advancement opportunities, and prioritizing education programs to build inclusivity and diversity competencies and awareness.

- Acting as advocates of Dana's inclusivity and diversity strategy and change agents for the organization — challenge thinking and the status quo.

Progress by the Inclusion and Diversity Governance Committee is reported on to Dana's Board of Directors twice a year and to the Technology and Sustainability Committee five times annually.

---

*"WHILE INCLUSION REFERS TO THE DANA BEHAVIORS THAT ENSURE PEOPLE FEEL WELCOME, DIVERSITY REFERS TO THE QUALITIES THAT MAKE PEOPLE UNIQUE."*

---



## SEVEN BUSINESS RESOURCE GROUPS DRIVING ENGAGEMENT

As a global organization, our people bring perspectives and opinions sourced from different cultures, backgrounds, and experiences that help to shape the Dana family. Listening to diverse voices and opinions gives Dana strength, enabling us to solve problems faster, think outside the box, and ultimately drive continuous improvement and profitable growth.

Dana has established an expanding network of Business Resource Groups (BRGs) to enhance Dana’s ability to develop, retain, and attract employees of varied backgrounds. They lend a voice to the diversity we have across all of Dana and increase the engagement of both our current and retired employees. In addition, they help to fulfill our commitment to being a good corporate citizen during our time at Dana and beyond.

By embracing inclusion and diversity, we create an environment that inspires the best from everyone and maximizes the value of our most important asset — each other.

*"LISTENING TO DIVERSE VOICES  
AND OPINIONS GIVES DANA  
STRENGTH AND ULTIMATELY DRIVES  
CONTINUOUS IMPROVEMENT."*

These BRGs are executive leadership-supported, employee-led initiatives with the mission to inspire growth and innovation and foster inclusion for all employees.

- African American Resource Group
- Dana Alumni Resource Group
- Dana Women's Network (DAWN) Resource Group
- Environmental Resource Group
- LGBT + Allies Resource Group
- Military and Veterans Resource Group
- New To Dana Employee Resource Group

### Military and Veterans Resource Group

In 2020, we added the Military and Veteran’s BRG, which is focused on the employees who currently and / or previously served in the military.

Key areas of focus include recruiting and retention, comradery and support, and community outreach. Activities encompass assisting veterans with transitioning from military positions to civilian positions. We job map Dana openings with capabilities (including strong technical skills) developed while serving, as well as participating in job fairs and other recruiting activities. We also seek to provide support to employees that have served or have family serving in the military in addition to partnering with veteran organizations and supporting events that honor and assist veterans in the community.

## BUSINESS RESOURCE GROUPS AT DANA

**A.A.R.G. African American Resource Group**



Alumni

Live Green

**DAWN**

★ ★  
Military and Veterans

LGBT

+ALLIES



New To Dana

## U.S. CORPORATE EQUALITY INDEX 2021

Over its 19-year history, the Human Rights Campaign (HRC) Corporate Equality Index (CEI) has helped promote adoption of equitable workplace policies, practices, and benefits for lesbian, gay, bisexual, transgender, and queer (LGBTQ) people in the United States and beyond.

The CEI rates employers providing supportive LGBTQ inclusion practices to more than 18 million U.S. workers and an additional 17 million workers globally. Companies rated in the CEI include Fortune magazine's 500 largest publicly traded businesses, and include more than 1,140 major U.S. companies.



The CEI rates companies on detailed criteria falling under four central pillars.

- Non-discrimination policies across business entities.
- Equitable benefits for LGBTQ workers and their families.
- Supporting an inclusive culture.
- Corporate social responsibility.

In the 2021 report, Dana once again scored 90 points on a 100-point scale. The average CEI score for all Fortune 500 companies increased to 76 points, up from 71 in the previous year. Since 2017, Dana's score has increased significantly, attributed to a strong focus on updating policies and procedures, as well as improving education and awareness through the LGBTA business resource group. We will continue to explore opportunities to improve in the Corporate Equality Index.

## DANA DNA

Equality and inclusion are part of our DNA. The LGBT + Allies Business Resource Group is just one example of our commitment and supports a vision where employees diverse in sexual orientation, gender identity, and gender expression thrive as their authentic selves.

During 2020, the LGBT + Allies group sponsored a variety of Equality Toledo events and the Toledo Pride festival at our corporate campus in the United States.

The group also partnered with Equality Toledo for an open panel discussion and attended the Out and Equal Workplace Summit conference for the first time.

*"EQUALITY AND INCLUSION ARE PART OF OUR DNA."*



# *Inclusion and Diversity Champions*

*Programs aimed at inclusion, diversity, and equity allow the best ideas to flourish, connect talented individuals from underrepresented backgrounds with opportunities, and empower the best organizations to thrive.*

*At Dana, we hold people accountable for improving diversity across the organization and celebrate individuals and teams that champion these goals and ideals.*





## DANA RECOGNIZED AS WINNING COMPANY BY WOMEN ON BOARDS

In March 2020, we were recognized by Women on Boards for being a Winning "W" company for 2019, with 33 percent female members on our Board of Directors.

The 2020 Women on Boards is the only education and advocacy campaign driving the movement toward accelerating gender balance on corporate boards of directors. Women on Boards has advocated for corporate boards of directors to be at least 20 percent gender diverse by 2020.

We are proud to be a part of the 52 percent of Russell 3000 companies that are current "W" companies, which is up from 43 percent in 2018. We will continue to make inclusion and diversity a top priority and celebrate the growth of gender diversity across the organization.



**Rachel A. Gonzalez**  
Executive Vice President,  
General Counsel, and  
Secretary of  
Starbucks Corporation



**Virginia A. Kamsky**  
Chairman and Chief  
Executive Officer of  
Kamsky Associates, Inc.



**Bridget E. Karlin**  
Global Chief Technology  
Officer and Vice  
President of IBM Global  
Technology Services

## DANA CELEBRATES INTERNATIONAL WOMEN'S DAY

Although gender equality takes on different meanings across the globe, the celebration of International Women's Day shares a universal goal — no matter where you are — to show support for all women.

In March 2020, Dana Women's Network held a Women's Day lunch and learn at World Headquarters.

Shelley Bridarolli, Senior Vice President Human Resources, led a discussion on "Realizing Your Purpose." Chairman and CEO, Jim Kamsickas, along with other attendees, wore purple ribbons in support of efforts by Dana's operations in Mexico to address violence against women.



DAWN

## DANA'S DAY OF UNDERSTANDING

As part of our Day of Understanding held in 2020, we encouraged teams to complete a course entitled "Understanding Unconscious Bias." As we look to continue this journey of fostering a culture of inclusion and engagement, we launched a follow-up module called: "Overcoming Your Own Unconscious Bias."

These training programs call for each of us to take a personal look at our own predispositions, conscious or non-conscious, and to engage in practical steps to recognize and overcome them.



## LATEST AFRICAN AMERICAN RESOURCE GROUP CHAPTERS

During 2020, Dana's African American Resource Group (AARG) welcomed three new chapters at our Lugoff, South Carolina; Pottstown, Pennsylvania; and Toledo, Ohio, facilities in the United States.

The Lugoff AARG focuses on community involvement projects. These include developing partnerships with local, historically black colleges and universities, and personal development for Dana employees. The chapter will also be implementing a mentorship program with a local elementary school.

The Pottstown AARG will focus on personal development for our employees, as well as education and community awareness through its monthly newsletter. In addition, it plans to sponsor quarterly community activities with an emphasis on increasing African American participation in local events, including the Soapbox Derby and RC cars.

The Toledo Driveline AARG will focus on community involvement within the city of Toledo, in addition to developing relationships with historically black colleges and universities. The group will also place a strong emphasis on personal development for our employees as well as education and community awareness through its monthly newsletter.

Meanwhile, our AARG in Maumee, Ohio, partnered with Acro Service Corporation in 2020 to award a scholarship to one of our mentee students who graduated from Rogers High School in Toledo, Ohio.

The recipient, Treyquan Eubanks, is now a freshman at the University of Toledo majoring in engineering. During his time at Rogers High School, he was honored for outstanding academic excellence while also serving as vice president of the National Honor Society and treasurer of the Student Council.





## *DANA PEOPLE PAUSE TO SHOW UNITY IN STOPPING RACIAL INJUSTICE*

In June 2020, our Chairman and CEO Jim Kamsickas invited the global Dana family to participate in moments of silence as a sign of solidarity and support for eradicating racial injustice all around the world.

Dana people from all around the world paused for 8 minutes and 46 seconds, the timeframe that has become symbolic in the movement for systemic change.

In 2020, observing this duration of time served as a very powerful and important opportunity for all of us to reflect on instances of wider racial injustices.

Facilities across the globe came together to demonstrate the importance of treating everyone with dignity, respect, and kindness at all times.

As an organization, Dana stands for inclusion and diversity. This means every person at Dana is responsible for ensuring that we cultivate an environment where differences are valued, all ideas are welcomed, and employees feel safe — physically, emotionally, and mentally — to discuss difficult topics, such as racial injustice, so that we can collectively find ways to eradicate it.



*"WE THANK EVERYONE WHO TOOK THE TIME TO SELF-REFLECT ON THIS IMPORTANT CAUSE AND TO ALL THE DANA TEAM MEMBERS WHO HELPED TO COMMUNICATE IT WORLDWIDE."*





# EMPLOYMENT DATA

## Gender

Employees by Gender<sup>1</sup>

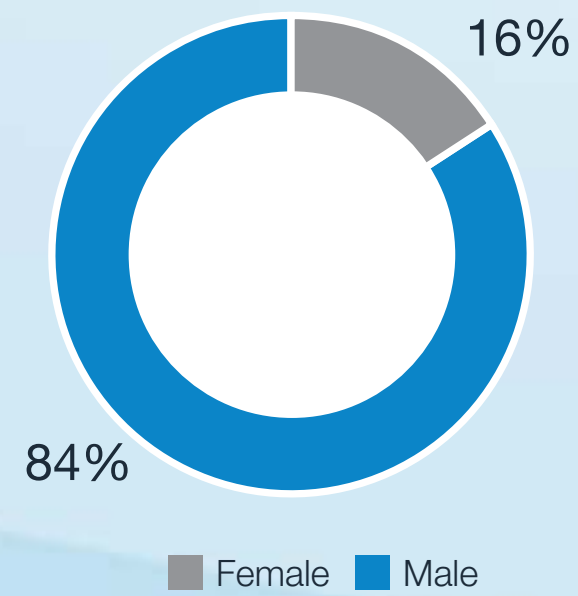

Employees by Employment Type and by Gender

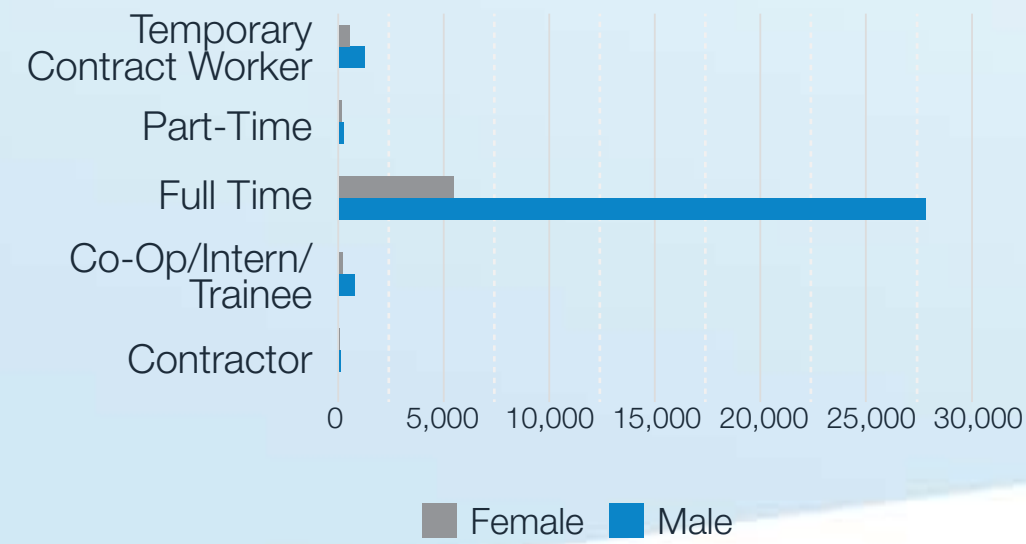

New Hires by Gender

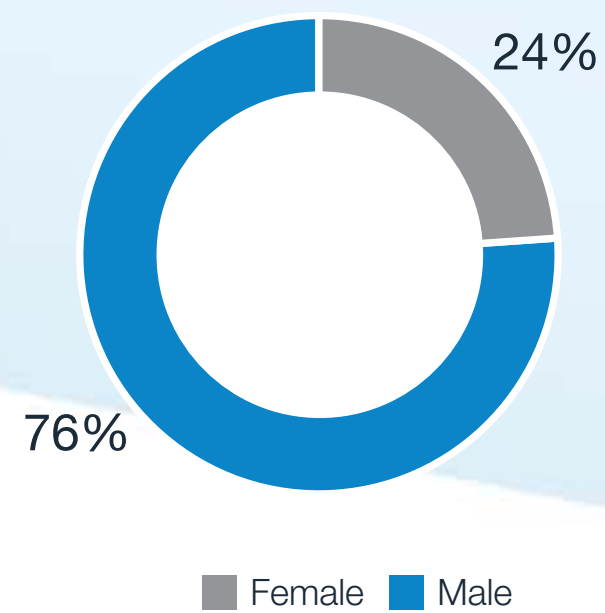

Attrition by Gender

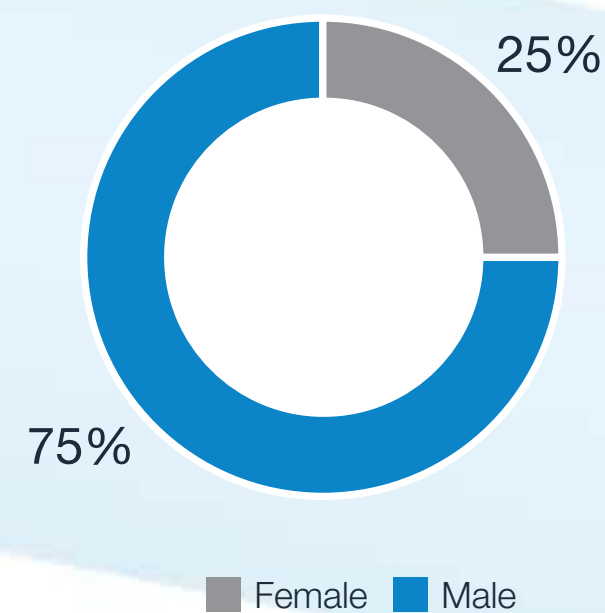

## Region

Employees by Region

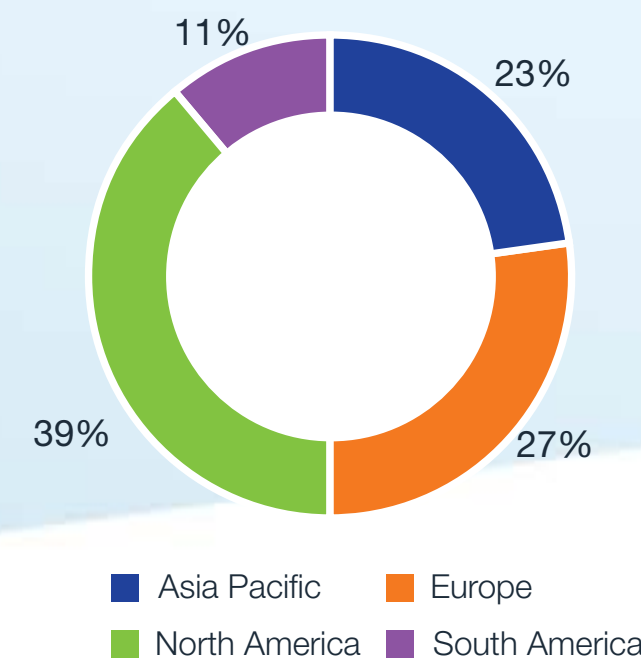

Attrition by Region

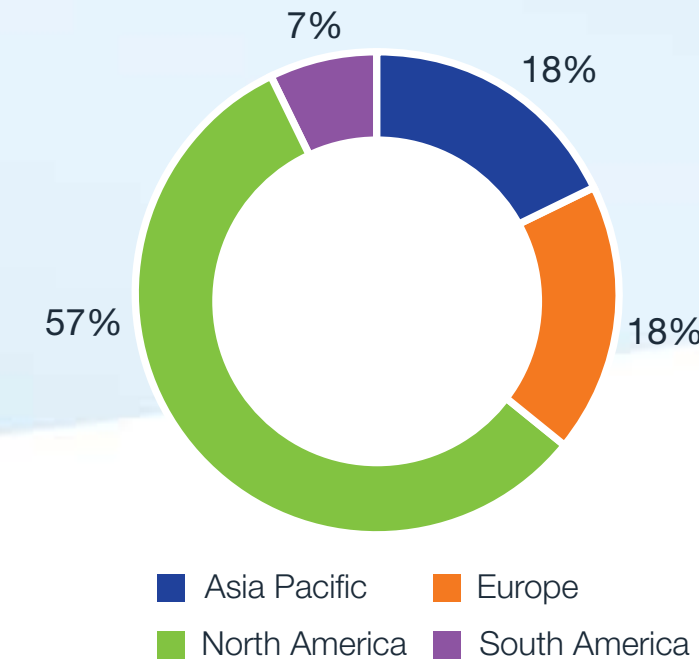

New Hires by Region

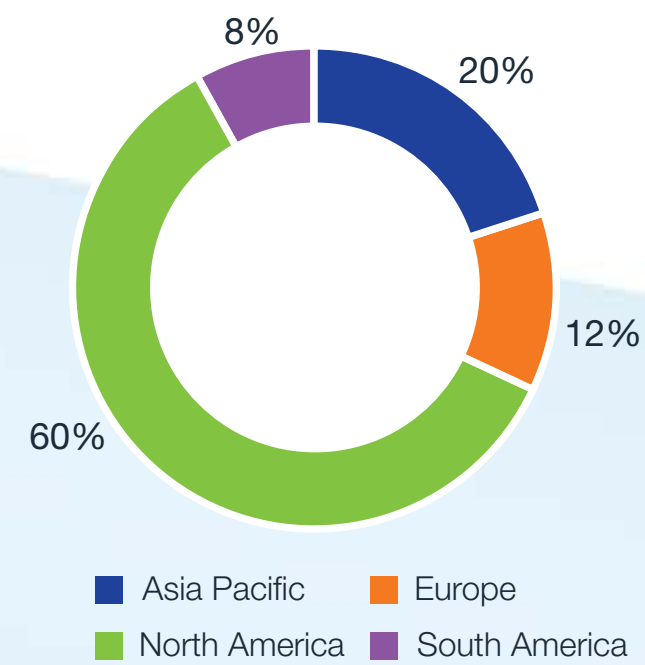

## Age

Attrition by Age Group

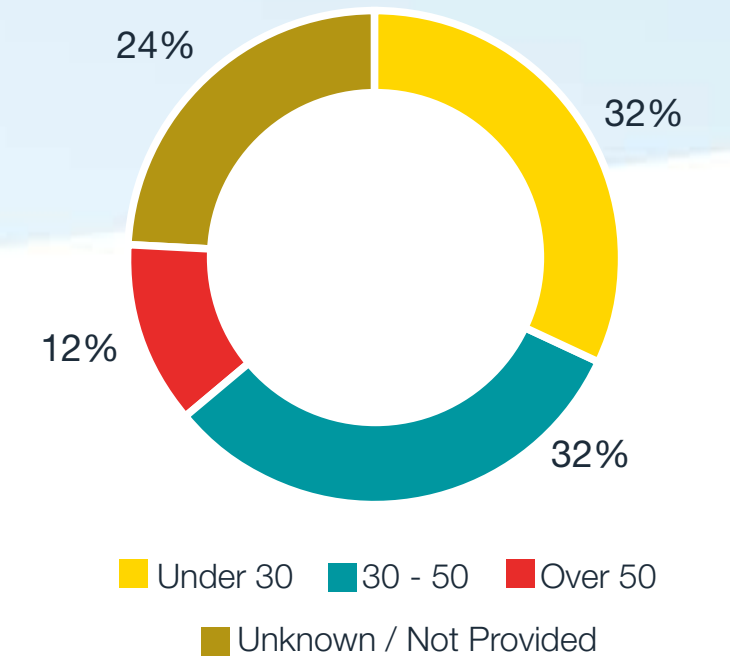

New Hires by Age Group<sup>2</sup>

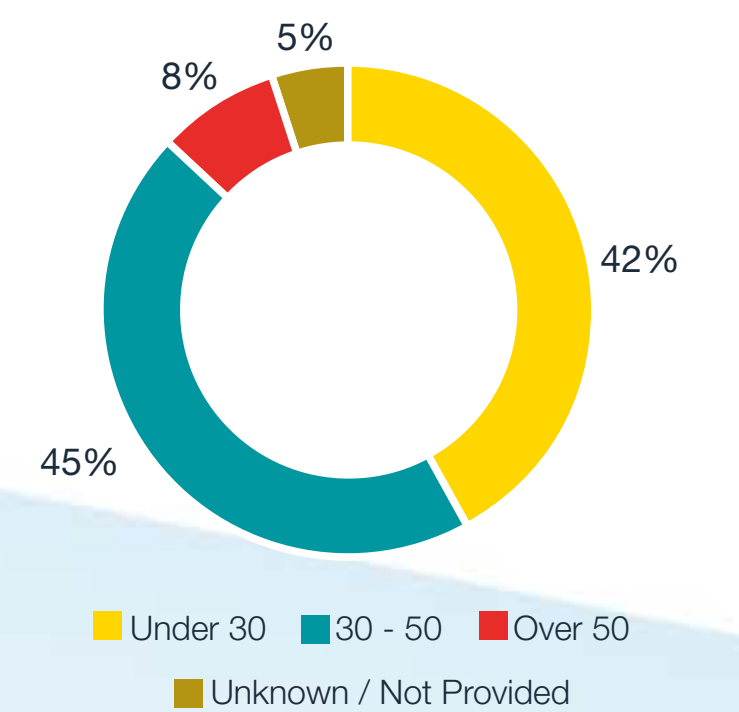

<sup>1</sup> Per Headcount Policy — vendor service workers, JV unconsolidated, employees on unpaid leave or layoff are excluded from headcount

<sup>2</sup> Date of Birth is not listed in employee count or employee is a contractor and is unknown/not provided. Contractor Date of Birth is not provided in employee count.

# People Development

## DANA TALENT

A reputation for employee satisfaction strengthens our brand, boosting our ability to attract and retain top talent. At Dana, we want our people to know that they can be innovative; receive career development, fair wages, and benefits; and see their contributions being valued — contributing to the long-term success of their career goals and to Dana’s achievements.

Globally, we offer employee health and wellness benefits in addition to incentivized compensation programs. A significant number of our people participate in plans that provide for annual performance-based bonuses through our company-wide incentive plan or through a bonus and / or profit-sharing scheme sponsored locally. Availability is somewhat dependent on the national remuneration practices where employees are based — but in most instances — these programs are available to both salaried and hourly employees.

Retention of our employees is critical to Dana’s success and the delivery of the products on which our customers rely. Once a new employee is onboarded and trained, retaining them means spotlighting the “Dana difference” — showcasing our work environments, culture, development opportunities, and employee recognition.

The knowledge, skill, and relationships that are developed with employees are of tremendous value to Dana and other team members. To engender a spirit of collaborative innovation, we support open communication opportunities allowing employees to deliver feedback, including engagement surveys, skip-level discussions, and interaction with the leadership team.

## DIVERSITY MIX

During 2020, our diversity sourcing and recruitment programs had a strong impact as we continually increased our connectivity and exposure to new partners and organizations in the market.

Our efforts primarily focused on impacting key groups that we measure from a representation standpoint, namely women and minorities. We remained committed to recruiting across other key communities and groups, such as the LGBTQ community. We also increased our focus on military and veteran hiring by partnering with a third-party specialist to increase our access to this valuable demographic.

We continue to track progress against our interviewing policy, which requires gender and racial / ethnic diversity among external candidates at Director-level and above in the United States. Our focus on women and minority candidates plays a critical role in hiring for leadership roles. We look forward to expanding this policy more broadly in the future.

---

*“RETENTION MEANS SPOTLIGHTING THE ‘DANA DIFFERENCE’ — SHOWCASING OUR WORK ENVIRONMENTS, CULTURE, DEVELOPMENT OPPORTUNITIES, AND EMPLOYEE RECOGNITION.”*

---

### Ben Kock

**Senior Manager**  
Environmental, Health, and Safety and Security



“My passion at work is to help make Dana stronger and safer. We certainly have some impressive ambition. Over the last few years, the Off-Highway business in Europe alone grew from 6,000 to almost 10,000 employees across 36 sites.”

“I think that this pandemic has revealed the true essence of the Dana team. We’ve worked so hard to make sure each other and our partners are safe. This has meant masks and social distancing to keep plants running securely. But beyond that, it’s a commitment to duty of care. To support mental wellbeing. To live the true spirit of Dana Cares in everything we do.”

*As an organization, we have a responsibility to set the tone and expectations around personal progression and we want all employees to have access to the tools and resources for their career development.*

Knowing how important continuous learning is to current and future employees, we offer multiple methods for training and development opportunities — online, instructor-led, and on-the-job learning formats — which help to shape critical career-building moments.

We believe the development of our people is critical to the company’s success and that stronger people means a stronger Dana. We therefore empower individuals to lead their development by articulating their professional, personal, and career growth aspirations to their manager.

### *PIVOTING IN THE PANDEMIC*

To continue supporting people development during 2020, we expanded the number of courses and training languages available, and shifted to online and on-demand modules. As the pandemic persisted, much effort focused on identifying which content would be most effective via online training by assessing the technology available, scalability, and the impact of digital fatigue.

*"WE OFFER MULTIPLE FORMATS FOR LEARNING AND DEVELOPMENT OPPORTUNITIES, SHAPING CRITICAL CAREER-BUILDING MOMENTS."*

With a significant number of Dana people working remotely, we also needed to ensure that teams had easy access to the online systems while maintaining a robust single sign-on protocol with multi-factor identification. SkillPort — a resource for Dana managers to improve their leadership skills in alignment with Dana's core competencies — was expanded from 150 courses to over 1,500 courses.

### Vanesa Badillo

**Senior Manager**  
Talent Development



“Sometimes in your career, you have to take a leap of faith. To get out of your comfort zone. For me, this involved moving from Dana’s Colombia operations after 15 years to managing global talent development at our World Headquarters in Maumee, Ohio, United States.”

“I work to ensure that we have the right talent, at the right place, at the right time. This means championing talent mobility and creating an agile culture where people can explore new opportunities. I always felt the backing and support from leadership to help me be successful, and with Dana’s scale and reach, I took true ownership of my career development.”

## LEARNING JOURNEYS

“Learning Journeys,” a monthly selection of online training sessions, was an important asset for the development of our employees during the year.

The subjects chosen each month encompassed career-progression planning to support the development and talent review process, mid-year review cycle, and preparations for effective performance discussions at the end-of-year review. Learning Journeys addressed the issues many of our people were facing while working from home. We looked at the tools for working remotely, virtual teamwork, managing stress, resilience, as well as other work, family, and individual well-being topics.

Learning Journeys also reinforced Dana’s ongoing efforts to build higher levels of inclusion and diversity. Each quarter, a new course was introduced to assist people with further understanding of unconscious bias, blind spots, and collaborating effectively with different work styles to reach the higher levels of creativity that inclusion and diversity bring to our culture.

Concepts from “The 7 Habits of Highly Effective People” were also introduced over a ten-episode series to increase both personal effectiveness and interpersonal aptitudes — valuable foundations of a strong leadership skillset.

## SAFETY, QUALITY, AND INCLUSION TRAININGS

As the pandemic evolved and essential workers started returning to the workplace, we created a course to detail the policies and procedures established to safely support our people.

This module was developed in multiple formats so that it could be deployed using varied delivery methods — to be played at a training kiosk, available online and / or delivered in a group setting. We also made available a template that could be modified and translated to address specific requirements, policies, and procedures needed at the local level.

To support Dana’s Quality Focused initiative, two trainings were created — one to provide an introduction and overview and the other to expand on Dana’s Life Quality Rules — key elements that underpin the initiative. Each course was developed in two formats, one to be delivered online and the other translated into 20 languages that could be presented in a group setting at the local level.

We also expanded the number of facilitators for our “Unlocking the Power of Inclusion” training programs and started teams in Brazil, Canada, and Mexico, while expanding our team in Europe, to deliver the program in a broader range of European languages.

The Respect in the Workplace module, part of the Operational Leadership training program, was made more interactive and incorporated facilitator notes and script so that it could be used by local leaders as a separate training program for all the people in their facility, to help reinforce Dana’s expectation of a respectful and inclusive working environment.

## MENTORING

Senior leaders around the world support Dana’s commitment to accelerate our people’s development by engaging in formal and informal mentoring partnerships. Increasing confidence, broadening perspectives, expanding personal and professional networks, and identifying career paths count as some of the many benefits for Dana mentees.

Our focus on mentoring is also extended to our communities. Members of Dana’s African American Resource Group volunteer as mentors for high-school and university students, as well as members of the National Society of Black Engineers.

Mentoring students helps to attract the best diverse talent and is also an opportunity for Dana mentors to develop and reinforce their leadership capabilities and give back to our communities.

# Health and Well-being

Health initiatives can have a long-lasting, sustainable impact on employee well-being, including enhanced creativity and dynamism, job satisfaction, and the ability to create a better work-life balance. For Dana, this means a more vibrant workforce, increased morale, talent retention, and a robust future for the company.

## Dana believes:

- In the importance of striving for personal and work-life integration.
- In a supportive work environment that cultivates the drive to succeed.
- In a willingness to explore new opportunities across the health and well-being spectrum.

We are committed to providing all of our employees with quality and competitive benefit programs, including health and wellness resources and decision-support tools to enable employees to make educated decisions regarding their health and well-being. Our plans are benchmarked annually to ensure fit, competitiveness, and value.

In response to the COVID-19 pandemic, Dana enhanced employee assistance programs around the world, including myStrength and Care.com programs that support the emotional health and wellness of our employees.

In addition to traditional employee assistance services, these programs also give employees access to legal services; dependent care support; financial advice and mindfulness programs, such as meditation, positivity-training tools, and inspirational videos to help manage anxiety, depression, stress, sleep and more.

“HEALTH INITIATIVES HAVE A LONG-LASTING, SUSTAINABLE IMPACT ON EMPLOYEE WELL-BEING, INCLUDING ENHANCED CREATIVITY AND JOB SATISFACTION.”



# Growing Stronger, Together

*As the world united to fight COVID-19 during 2020, Dana's top priority was always the health and safety of our employees, our communities, and our customers.*

We felt the power of the Dana family, not just from the formal actions implemented across the organization to navigate the crisis, but also the individual behaviors that have made a significant impact on the safety and welfare of our people. Together, we have worked to ensure that we remain safe and act responsibly whether on the job or in the communities that we call home.

To this end, we implemented numerous pandemic-related protocols throughout our global operations to further ensure health and safety across more than 140 facilities in 33 countries. These actions included restricting access or temporarily closing a significant number of our plants, increasing cleaning and disinfecting protocols, utilizing personal protection equipment, adhering to social distancing guidelines, instituting remote work, and restricting travel.



## EMPLOYEE EXPERIENCE

These unprecedented times fundamentally challenged how Dana leaders engaged with their team members and addressed new concerns about stress, health, safety, financial wellness, and work-life balance.

To understand the implications of COVID-19 on the employee experience, Dana participated in global research which provided leaders and local management teams with insights on how to shape the organizational strategy to support fast recovery, and ultimately prepare for the new normal.

The study focused on four main dimensions — concern and connection, virtual work effectiveness, employee wellness / health and safety, and senior leadership response and communication — and across each category Dana scored favorable feedback.

## Karen Shears

### Manager

United Kingdom and Ireland HR



“For me, the Dana way is about being supported and having the freedom to be creative. We’re implementing some important projects that have a real impact on employee well-being. I am particularly proud of introducing Mental Health First Aiders across the U.K., together with other initiatives focusing on employee development and culture.”

“Over the last two years, the number of Dana sites in the U.K. and Ireland has grown from two to seven. A significant part of my role is to champion a better world of work for our employees. The recent Top Employer Europe award is a testament to our ambitions as we strive for excellence every day.”

Through it all, we communicated on a regular cadence with our teams so they felt confident, whether they were working safely in a Dana facility or from their homes — enabling quick and decisive action to protect our people while serving our customers.

Ultimately, our manufacturing facilities did their part to ensure that the critical mobility industry could continue to operate during the pandemic. We helped to keep the world moving by supplying elemental components to essential vehicles such as ambulances, food harvesters, and material handling equipment.

Accordingly, we expanded our safety protocols, including implementing employee and visitor health self-checks and temperature monitoring, stringent disinfecting and hygiene practices, increasing facility air exchanges, further separating employees from one another and asking employees who can do their job remotely to work from home.

In addition, our global teams delivered tirelessly in acquiring the necessary PPE and other protective supplies as we worked toward bringing more facilities safely back online.

We have and will continue to follow government and health officials' guidelines — locally and globally — to ensure that we are doing everything in our power to keep our employees safe.

## SELFLESSLY COLLABORATING

While we proved agile in adapting to the pandemic, many of the core anchoring tenets of how we work have remained the same. These revolve around staying connected within our engineering and manufacturing teams through constant, consistent, and clear communication to drive the company forward in these challenging times.

Dana has been implementing cloud-based productive platforms and cybersecurity tools for some time. The pandemic has amplified these demands, requiring us to rapidly deploy laptops to teams throughout the world while leveraging the full capabilities of video conferencing to keep in touch with our customers and suppliers. Open and honest communication, in its various forms, has long been a foundational value of Dana.

## CREATIVE SOLUTIONS

As a technology company with a 117-year history, we have a culture of innovation that anticipates industry trends and challenges.

During the height of this pandemic, many of the world's health systems were — and sometimes still are — in dire need of equipment to protect health care workers.

---

*“WE FELT THE POWER OF THE DANA FAMILY, NOT JUST FROM THE FORMAL ACTIONS IMPLEMENTED, BUT ALSO THE INDIVIDUAL BEHAVIORS THAT HAVE MADE A SIGNIFICANT IMPACT ON THE SAFETY AND WELFARE OF OUR PEOPLE.”*

---

Not only did we manage through the operational challenges of the pandemic with more than 100 facilities temporarily idled, but our teams around the world also applied their expertise to support frontline workers, including manufacturing personal protective equipment and critical components for ventilators.

At our Advanced Manufacturing Center in Maumee, Ohio, United States, our engineers designed, tested, and produced a 3D printed face shield for local healthcare professionals in less than a week. We used our engineering expertise to reduce the amount of material needed to produce a version that is strong, durable, and lightweight that could be sterilized and reused. We were proud to work alongside many front-line providers and great partners in our communities.



We also helped to develop a plexiglass enclosure that allows doctors and nurses to have full visibility of and access to the patient during intubation and extubation. The device can be sanitized and used multiple times. In order to create more impact outside of Dana's local communities, we made the face shields and intubation enclosures open source by allowing the designs to be freely downloaded on [Dana Cares](#).

Our global purchasing team helped hospitals to source critically needed personal protective equipment, such as gloves, shoe covers, glasses, and masks to help protect medical professionals and first responders.

In China, we donated 50,000 masks to the local governments in Hubei Province and the Dana Charitable Foundation in the United States also donated financially to organizations such as the United Way and Red Cross, which are on the front lines of fighting the COVID-19 pandemic.

These are just a few examples of the extraordinary efforts that were made by Dana team members all around the world. We also have countless individuals who are helping their local communities by volunteering their time, giving blood, donating money, delivering food, or even making masks. Whatever is needed to make a difference.

*“AS A TECHNOLOGY COMPANY WITH A 117-YEAR HISTORY, WE HAVE A CULTURE OF INNOVATION THAT ANTICIPATES INDUSTRY TRENDS AND CHALLENGES.”*





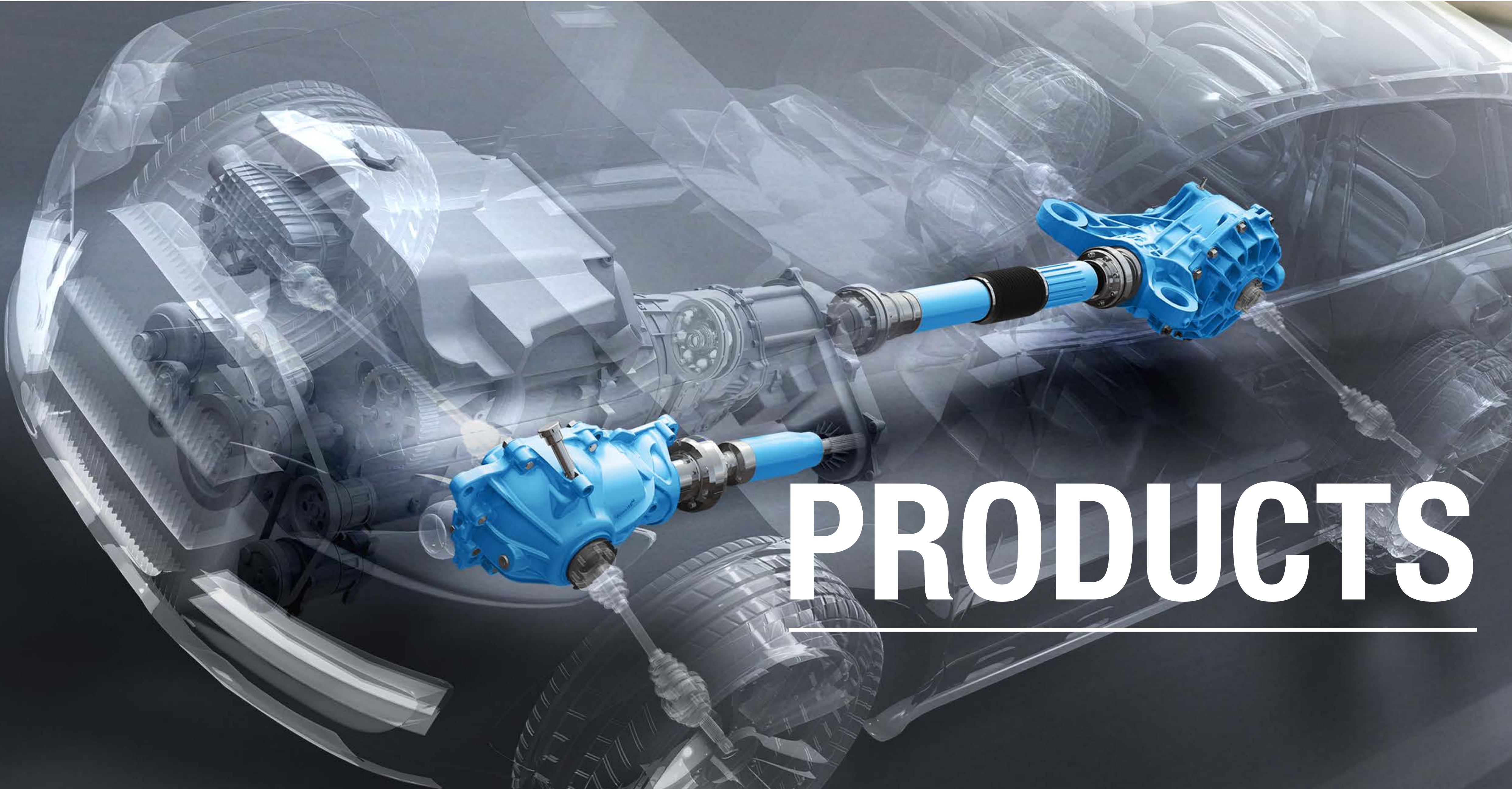

# PRODUCTS

# Quality Focused All Day, Every Day

Building quality and safety into our products and processes are foundational considerations at Dana. Our strategy of “Quality Focused All Day, Every Day” was reinforced with all Dana team members and was followed-up with compulsory global training modules.

This reflects a methodology of the customer being at the center of everything we do. Exceeding customer satisfaction with a culture of quality and a zero-defect mindset is core to our "One Dana" approach.

Our Quality Focused strategy empowers our teams with standard tools and processes to improve our sustainability footprint through waste elimination in our production processes.

---

*“EXCEEDING CUSTOMER SATISFACTION WITH A CULTURE OF QUALITY AND A ZERO-DEFECT MINDSET IS CORE TO OUR ONE DANA APPROACH.”*

---

## WHY QUALITY FOCUSED MATTERS

By building in quality and doing it right the first time, we reduce the opportunity for non-conforming material and future warranty claims.

Our products and processes provide essential mobility services for people around the world. This is why Dana’s product safety protocols ensure that deliverables meet or exceed global vehicle safety requirements.

Through “Stop and Fix,” we are empowered to stop the line and identify a potential risk or issue. Being customer focused through quality governance and our management system, we engage with all team members in making quality a priority every day.

Across our manufacturing processes, Dana invests in technologies that support a Quality Focused approach. This includes Manufacturing Execution Systems that incorporate software solutions ensuring that quality and efficiency are built into our production processes.

## Lonnie Holmquist

**Vice President**  
Global Quality



“I think it’s important that where you work reflects your values. My family has been recycling for more than 30 years. We care about our footprint and the world around us. I see that same engagement when it comes to protecting Dana customers and having a defect-free mindset.”

“This is a team that’s always driving to the next level. Quality focus is a big part of our story and shapes how we work every day. I’ve found that you can make your Dana career whatever you want it to be. When you get the backing to launch enhanced quality training for 38,000 people — that’s a real vote of confidence in your work.”

These applications are proactive in early detection of potential issues and eliminate the opportunity to pass on a defect. In addition, product traceability is a key requirement at Dana. If an issue arises, traceability enables us to track potential units to a specific build rather than a build window.

Dana's Quality Operating System is based on existing industry, quality, customer, and technical standards. The system includes the entire product lifecycle, from initial concept through design, development, production, and post-production support.

It is comprehensive in design and inclusive of Environmental and Health and Safety management processes, utilizing a connected system of tools and methods that are tied to quality-focused behaviors and operational excellence.

Our Corporate Product and Systems Safety Policy is a cornerstone of our Quality Operating System and drives our commitment to product safety throughout the lifecycle.

As we grow our electrification portfolio — including motors, inverters, and controls — we are continually expanding the use of quality systems earlier in the process to address controls, detection, and compliance.

This allows us to address the needs of our customers in this rapidly growing market segment and deliver of all elements — from a component level to a complete, fully integrated electrified system — across any mobility market in any region of the world.

# Quality *Focused*

*All Day Every Day*



## QUALITY AWARDS: EXTERNAL SPOTLIGHT

*Recognition from our customers for the quality of work we are delivering is one way we know we are reaching the mark.*

### Dana Brazil Awarded Quality Master Award by Mercedes-Benz Mexico

For the second consecutive year, Dana's driveshaft operations in Gravataí and Sorocaba, Brazil, received the Master of Quality award from Mercedes-Benz in México. This prestigious honor recognizes outstanding performance in quality and delivery of driveshafts for Mercedes-Benz buses.



### Dana Querétaro Plant Earns Masters of Quality Award

In November, the team at Dana's Querétaro plant in Mexico was honored by Daimler Trucks North America (DTNA) with a Masters of Quality Award. The award honors the top component and service suppliers to Freightliner Trucks and Western Star brand trucks.



Established in 2011 to improve the quality of products and services, the award recognizes outstanding suppliers that have received high scores based on their quality, delivery, technology,

and cost performance as measured on a Balanced Scorecard basis. These suppliers demonstrate dedication to continuous improvement of the quality of their products, support to DTNA and overall performance.

### Off-Highway Plants Earn Quality Recognition from John Deere

In October, four of Dana's Off-Highway facilities earned recognition from John Deere as Consistent Best Performers for their exceptional focus on quality. Recognized were Dana operations in Wuxi, China; Sterling, Illinois, United States; Kohlapur, India; and Gravataí, Brazil.

To earn this prestigious recognition, a facility must have been in the Quality Best in Class quartile 1 for three consecutive years or four of the last five years. By achieving this milestone, it puts the facilities in a leading position for quality compared with their peers.





### Dana's Győr Driveline Facility Recognized as Champion of Quality

In October, Dana's Győr Driveline facility in Hungary was named a Champion for Quality by EASE Inc. The team was recognized in the "Trailblazer" category, which identifies nominees who use the EASE software for more than just layered process audits. The Győr team extended the system capability by leveraging it for processes such as safety audits, 5S, Covid-19 audits, and more.



The facility undertakes approximately 500 audits per month and during an average month, 10,000 individual checks are made. If any non-conformances are found, they are rectified within hours.

### Dana's Wuxi Plant Receives GM BIQS Certification

In September, Dana's Power Technologies facility in Wuxi, China, was certified for Built-in Quality Supply or BIQS by SAIC General Motors (SGM). The supplier quality program was instituted by General Motors in 2016, replacing its Quality Systems Basics program, and assesses suppliers according to 30 different elements in addition to IATF 16949 certification.

It includes metrics such as quality problem reporting and resolution, field actions, disruptions, and severity score. To be certified, suppliers must achieve a Level III score with each element scored based on a green, yellow, or red rating.



Through the process, the Dana Wuxi team worked closely with SGM to ensure the requirements of each module of BIQS was correctly deployed providing a unique opportunity to combine the quality standards and special requirements of our customer into Dana's operation system.

### Dana Wellingborough and Crescentino Earn Platinum Level Recertification from Caterpillar

In July, Dana's Wellingborough, United Kingdom, and Crescentino, Italy, facilities earned the highest Platinum Level Certification from Caterpillar for their Supplier Quality Excellence Process (SQEP).

As a key supplier, Dana plays an integral role in driving a "zero-defect" mentality into the supply chain management processes. This approach combines industry-proven quality system and process management requirements from ISO/TS16949: 2002 with demonstrated results to ensure expected capacity and performance.

Caterpillar's certification levels include Bronze, Silver, Gold, and Platinum. Suppliers are certified through SQEP by meeting or exceeding stringent supplier performance standards, such as product quality and shipping performance, which are measured over a year by a cross-functional global team of Caterpillar experts in the areas of engineering, manufacturing, logistics, and procurement.



**Dana Recognized by General Motors as a Supplier of the Year for Both Driveline Technologies and Powertrain Cooling**

In June, Dana earned General Motors Supplier of the Year honors for both its driveline technologies and powertrain cooling solutions during a virtual ceremony honoring the recipients of the company's 28th annual Supplier of the Year awards.

This is the third consecutive year Dana has received the award. The Supplier of the Year award winners were chosen by a global team of GM purchasing, engineering, quality, manufacturing, and logistics executives.



**Dana Facilities Recognized for Outstanding Quality by PACCAR**

In May, several Dana facilities were recognized by PACCAR for outstanding quality by consistently delivering parts and components that meet or exceed PACCAR's 10 PPM quality performance requirements.



Dana's Sorocaba, Brazil, facility was honored for the fourth year in a row. In a letter sent to the team, PACCAR stated their global reputation for quality is because of suppliers like Dana who consistently provide outstanding quality and service.

In addition to Sorocaba, Dana operations in Neu-Ulm, Germany; Danville, Kentucky; and Sterling, Illinois, were also honored with the award.

**Dana Rovereto Receives Platinum Award from Caterpillar**

In March, Dana's Rovereto, Italy, plant earned the Platinum SQEP certification from Caterpillar. The SQEP award certifies the plant's performance over the last year based on quality and logistic metrics that include parts per million rejected, percent of dollars rejected, percent of Production Part Approval Processes completed on time, and supplier shipping performance for production and service parts.

The Rovereto team has received the bronze and silver level of SQEP certification from Caterpillar in the last six years and is proud to have received the highest-level certification this year. The plant continues to supply quality and logistic excellence in the production of axles for the Caterpillar facility in Leicester, United Kingdom.



Dana Rovereto, Italy

## QUALITY AWARDS: INTERNAL SPOTLIGHT

*Just as safety is a fundamental part of Dana's continuous improvement culture, quality is also essential to our business. The products we make are safety-critical components in our customers' vehicles.*

*When combined with our Safety First initiative, our global Quality Focused strategy that is deployed across the entire organization sends a clear and consistent message about who we are and why our customers can always trust us to provide them the world-class quality and service that they deserve.*

### Corporate Campus Quality Focused

In November, Dana's corporate campus, which includes our World Headquarters, Advanced Manufacturing Center, and Global Information Technology Center in Maumee, Ohio, and offices in Novi, Michigan, recently completed the International Automotive Task Force or IATF audit.

The scope of the audit includes the design and development of both traditional and electrified drivetrain and powertrain products, adjacent technology components, and advanced chassis control systems for original equipment and service applications in the on-highway and off-highway markets.

Developed by the International Automotive Task Force, IATF 16949 is a global quality management system standard for the automotive industry. It incorporates the structure and requirements of the ISO 9001:2015 quality management system standard with additional automotive customer-specific requirements.

The scope of the audit includes the design and development of drivetrain and powertrain products, adjacent technology components, and advanced chassis control systems for original equipment and service applications in the on-highway and off-highway markets.

### Toluca Hosts Month of Quality

In October, the team in Toluca, Mexico, had a "Month of Quality." The purpose of this event was to raise awareness of Dana's quality initiatives and remember the importance of listening to the voice of the customer.

Over the course of a month, everyone participated in various activities including contests, special quality training sessions, conferences, and workshops, as well as a teamwork tournament all centered around quality. Each event was designed to reinforce quality basics, strong ethics, product knowledge, positive and negative feedback, and the understanding of Dana's Quality Focused initiative.

### Quality Focused Global Training

In September, we launched enhanced Quality Focused mandatory training for all Dana associates — the goal being to ensure that every Dana person understands why building quality into our products and processes not only improves our manufactured capabilities, but ultimately protects our customers and our business.

These modules outlined the strategic fundamentals of the strategy, including communication, culture, life-quality rules, and standard tools for success with the goal of optimizing operational excellence across every Dana facility around the world.



Dana Toluca, Mexico



# Global Technology Center Network

## COLLABORATIVE INNOVATION ACROSS GLOBAL NETWORK OF TECHNOLOGY CENTERS

Dana's global technology centers are home to more than 2,200 of the world's leading engineers, technicians, and scientists dedicated to breakthrough advances that empower mobility and industrial customers.

A Dana DNA centered around collaborative innovation helps to anticipate, understand, and shape market trends and fast-track new products — partnering with those who think without limits to deliver novel, industry-shaping ideas.

Disciplines around mechatronics, software development, cyber security, systems engineering, and electromagnetics shape a distinctive competency portfolio of shared expertise.

Our diverse teams around the world strive for technical leadership and welcome challenges with a curious and open mindset in all that we do. This means prioritizing safety and high-quality delivery, innovating relentlessly, partnering with universities and start-ups, and leveraging new technologies and business models.

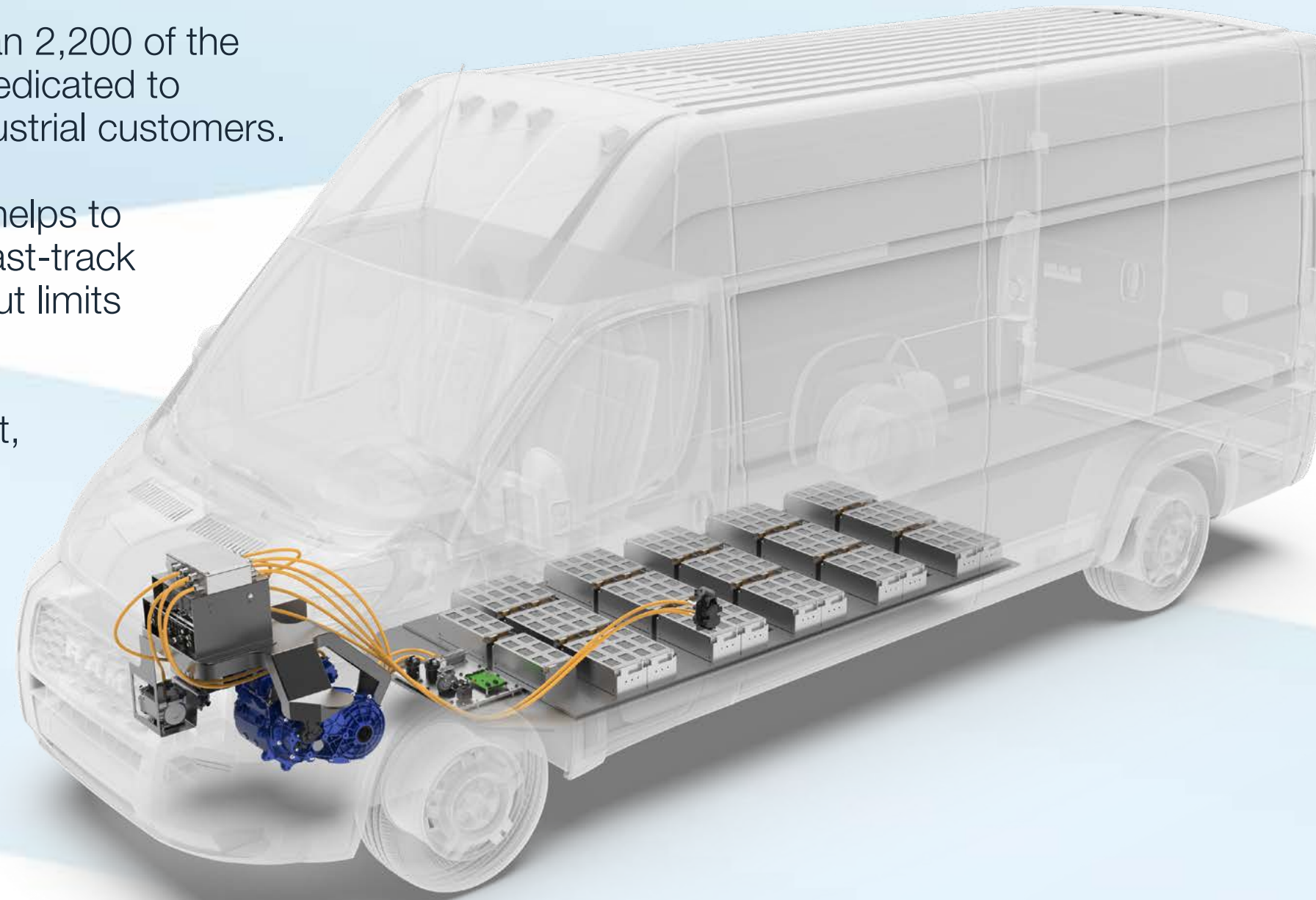

Hong Yang, Ph.D.

**Senior Director**  
Electric Vehicle Systems  
Engineering



“I believe that vehicle electrification holds the key to sustainable future mobility. Increased consumer demand and policy evolution are shaping rapid mass market adoption. In the commercial-vehicle space, product robustness, total cost of ownership, and infrastructure readiness are key drivers.”

“At Dana, we are uniquely positioned to support OEMs across all end markets at any stage in their electrification progression, with individual modules or complete, fully integrated systems. It's a pleasure to be at the center of this technical and sustainable revolution. I take great pride in seeing my team's production and manufacturing prowess every day and working with customers to anticipate every step of the innovation journey.”



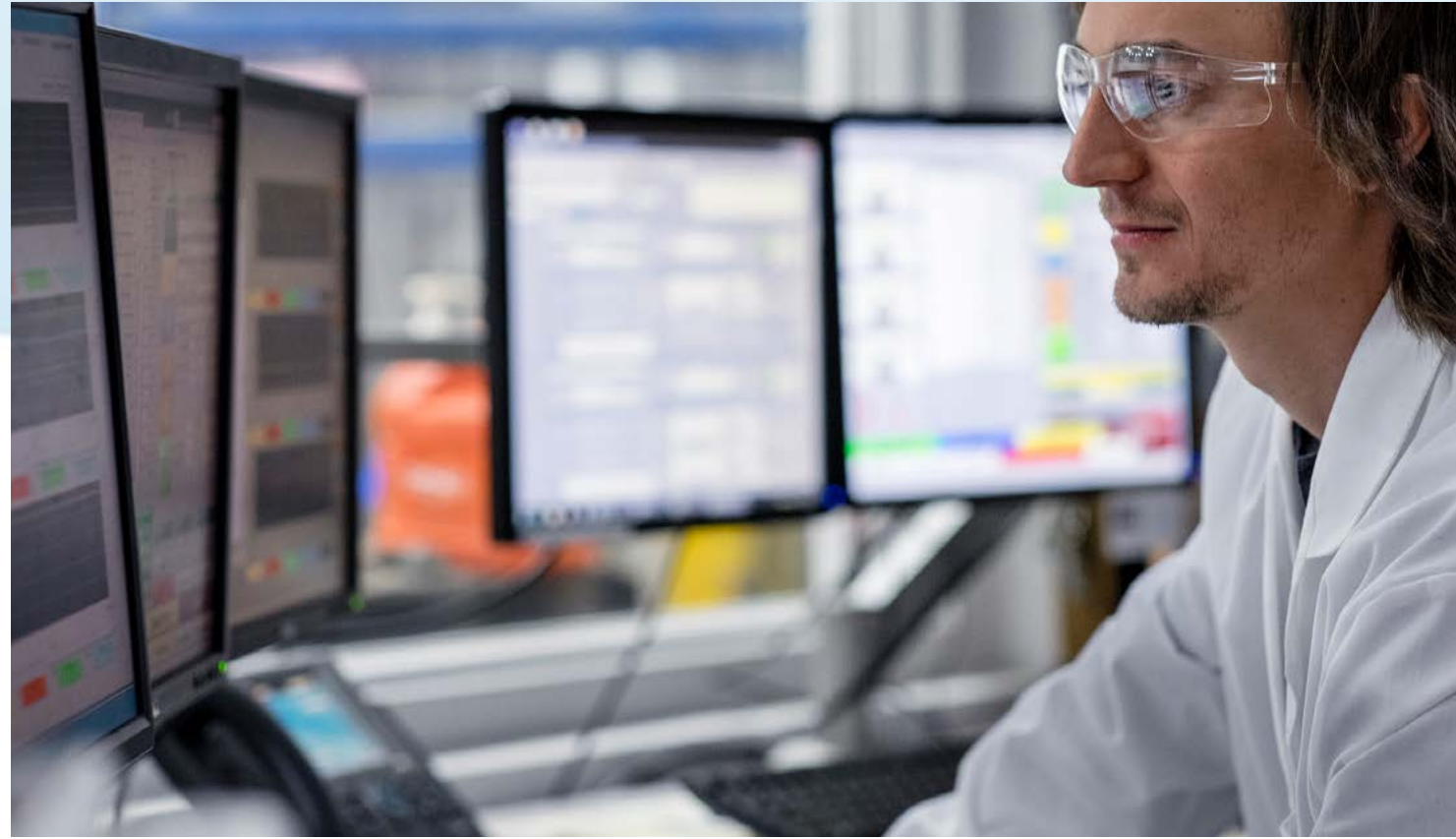

### Greater Than the Sum of Our Parts

We collaborate among our global mechatronics technology centers to drive diversity, deepen our understanding, push new boundaries, and deliver for customers. Recent acquisitions including — Ashwoods, Nordresa, Oerlikon Drive Systems, Pi Innovo, Rational Motion, TM4 — expanded Dana's footprint by 11 technology centers. This further enhances our ability to deliver on-the-ground, local solutions for customers as they continue to accelerate their electric vehicle portfolio development.

[Read more](#)



### Agile Development

Dana's journey into electrification has been more than 50 years in the making. Along the way, agile development became a big part of our story helping us to create alignment between business planning and IT execution, deliver value faster, foster innovation, de-risk solution delivery.

[Read more](#)

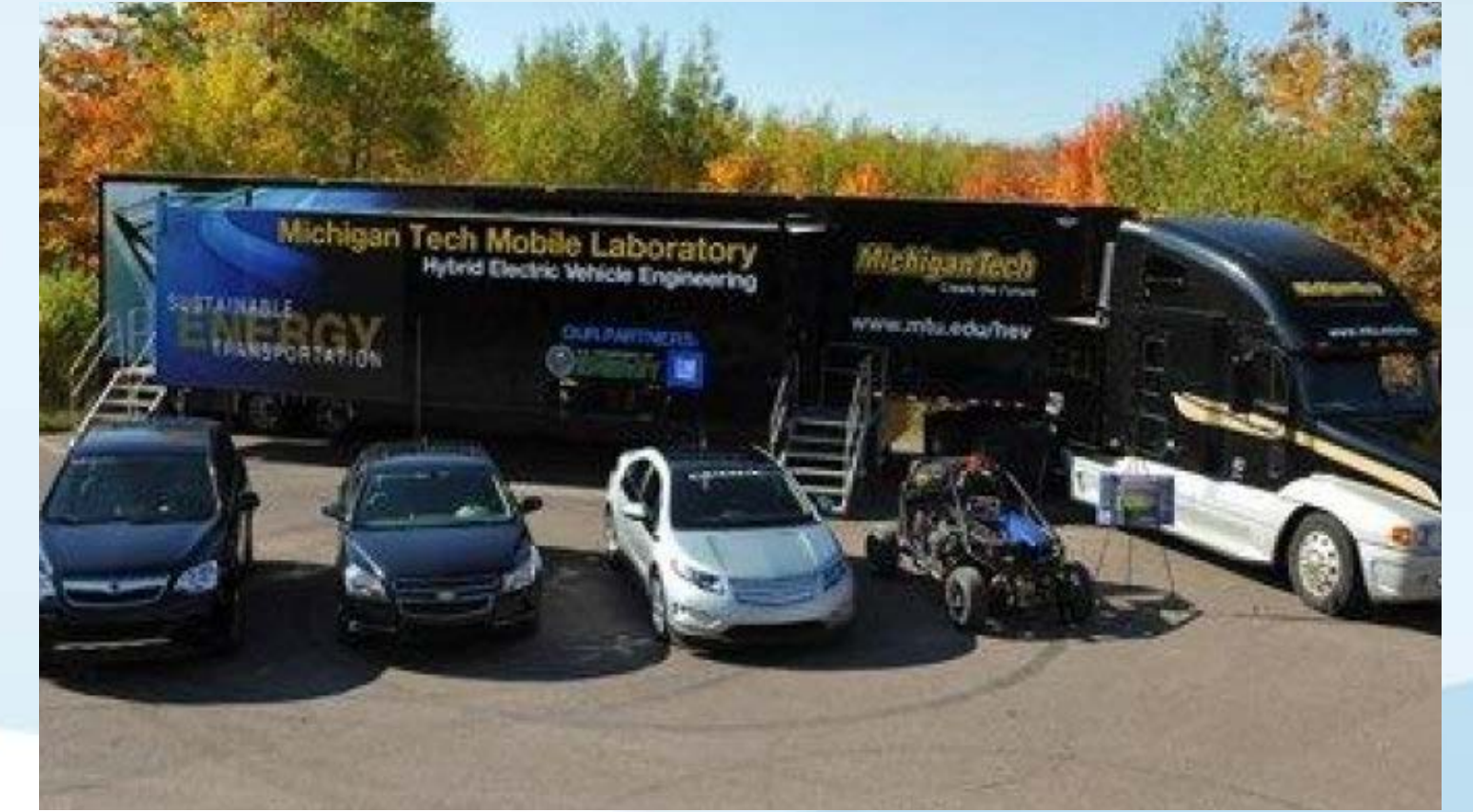

### Academic Partnerships

We recognize the importance of strong relationships with our academic partners. Our global network of universities throughout the Americas, Europe, and Asia provides a path for research and development, professional development education, and career opportunities transforming the future of mobility.

[Read more](#)

## GLOBAL TECHNOLOGY CENTER NETWORK



**GLOBAL NETWORK**

Strategically located across nine countries to ensure proximity to customers, our technology centers employ the methods of agile startups, dedicated to the pursuit of innovative, high-value solutions and new product optimization across all end markets.

This includes co-innovating with our partners to shape the next generation of mobility technology and anticipating every step of the innovation journey through advanced engineering, product development and support, and business expansion.

# Electrification. Delivered.<sup>TM</sup>

Dana is the only supplier capable of delivering all elements of a complete, fully integrated electrified system across all mobility markets.

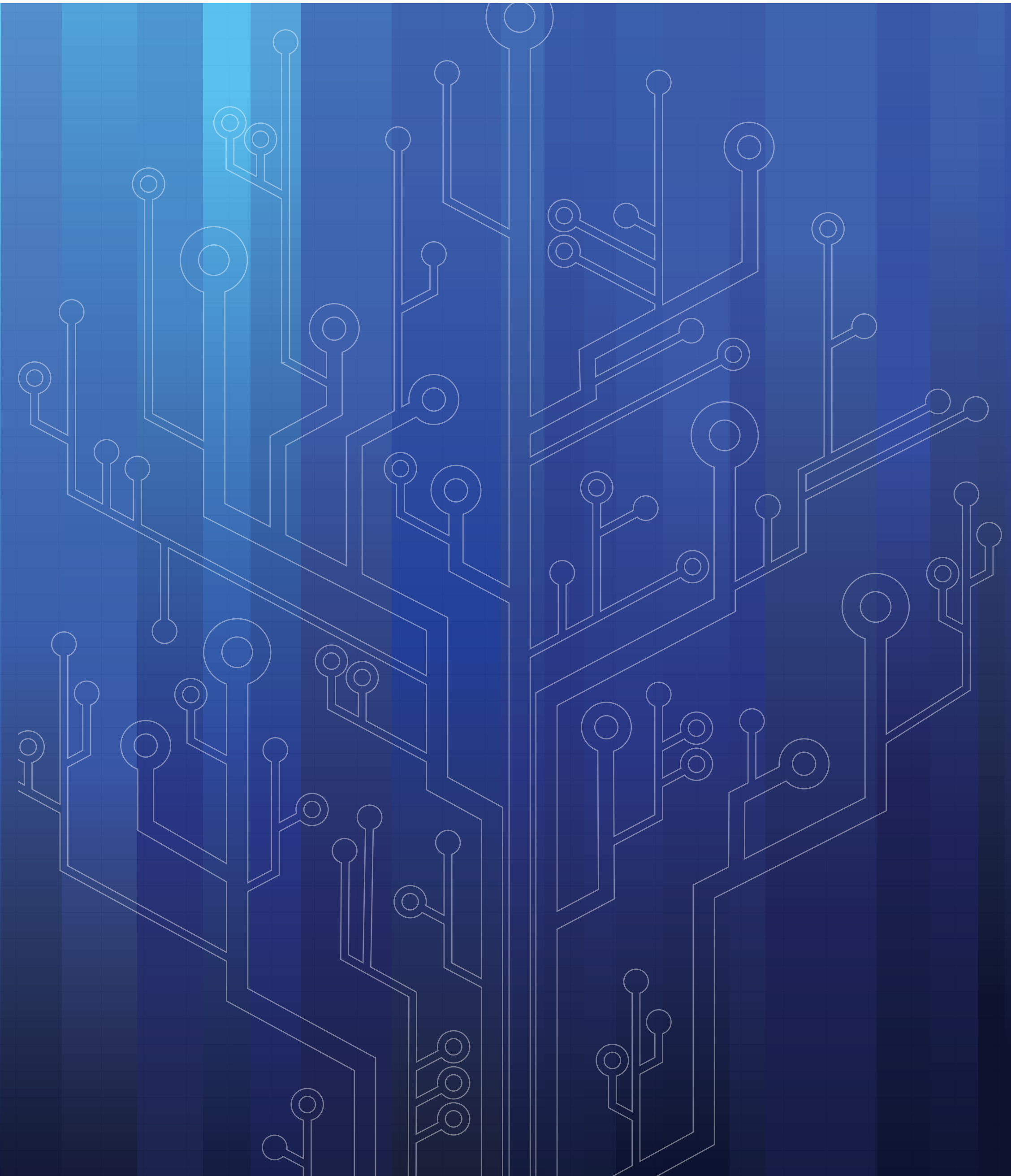

## ELECTRIFICATION. DELIVERED.™

In 2020, we continued to elevate our leadership position in the e-Mobility space, launching new electrified systems across all mobility markets. We also expanded our global electrification presence with the opening of a new motor, inverter, and controls manufacturing facility in India.

Our recent acquisitions continue to enhance our ability to seamlessly integrate software and controls into our entire portfolio of technologies, ultimately enhancing the flexibility, robustness, efficiency, and safety of vehicle systems.

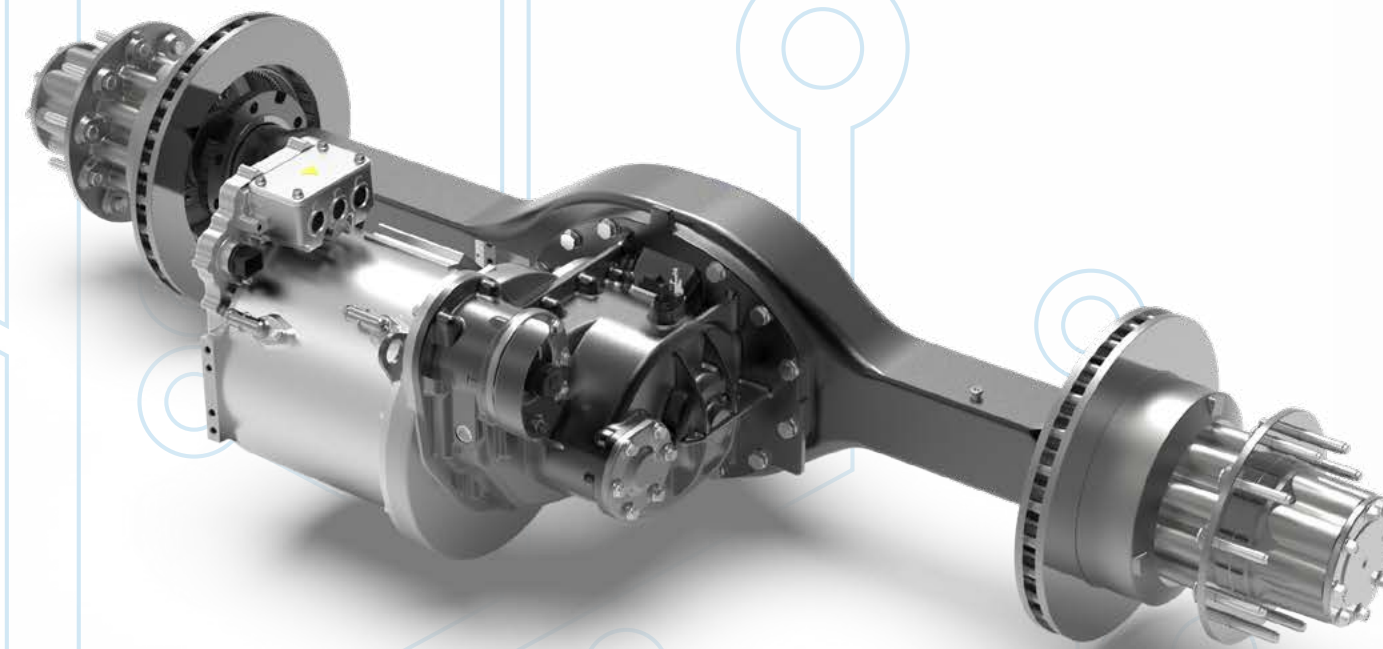

### Spicer Electrified™ e-Axle

The new Spicer Electrified™ eS9000r e-Axle for Class 4 and 5 medium-duty fleet applications is currently in production. Dana was the first to market in North America with this e-Axle classification and is ready to support widespread deployment of this streamlined e-Propulsion system.

Designed for medium-duty truck and bus applications, the eS9000r is based on proven and widely specified Spicer® rear drive axle platforms and is engineered as a fully integrated e-Axle, including a gearbox and motor.

The e-Axle is easily incorporated into most existing chassis, reducing driveline complexity while allowing batteries to be located between the frame rails to simplify truck body positioning. This e-Axle also incorporates our patent-pending electronically controlled parking pawl system.

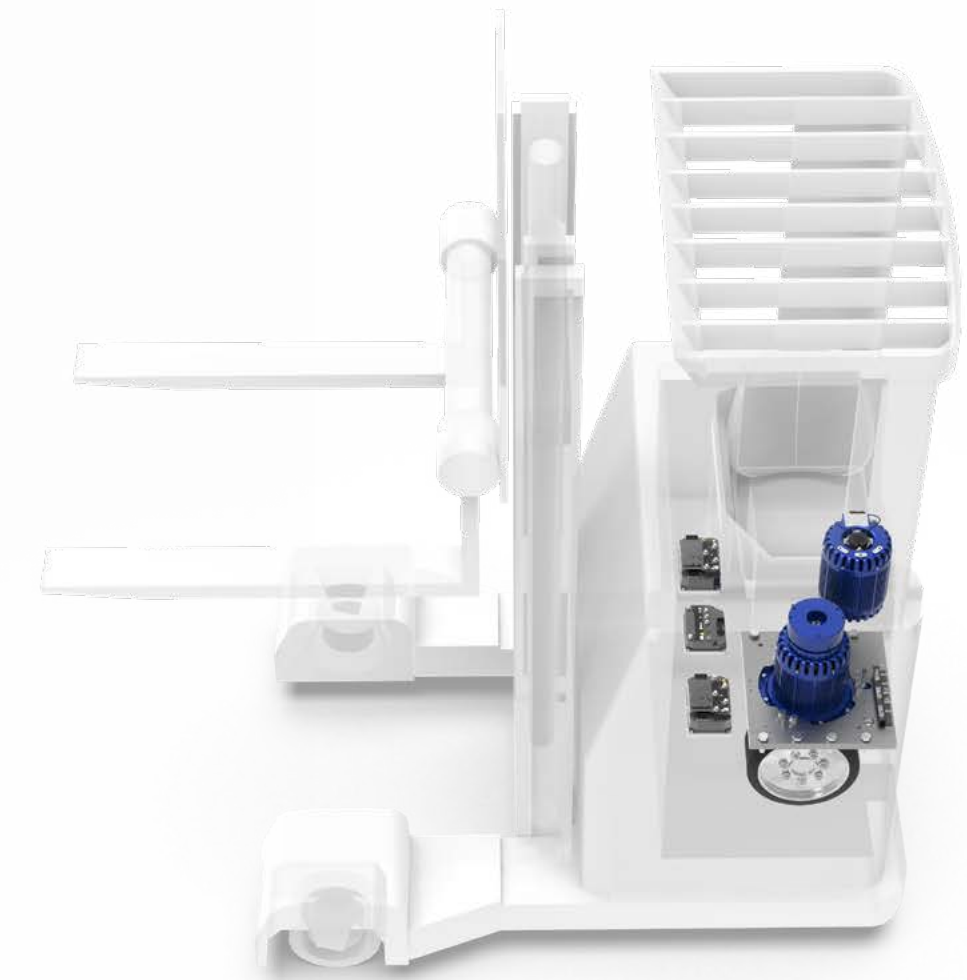

### New Electric Motors for Material-handling

In 2020, we launched a new electric motor targeted for Class I electric lift trucks, sideloaders, and mobile elevated work platforms.

Currently in production, these new low-voltage, high-efficiency motors offer continuous power from 20 kW to 60 kW, and peak power from 30 kW to 70 kW. They can be combined with Dana's inverter, controller, software, and drive products to deliver comprehensive system solutions for many types of material-handling equipment.

Delivering up to 95 percent efficiency, these 48- to 120 / 144-volt synchronous reluctance internal permanent magnet motors prolong battery life and extend duty cycles by delivering higher power density than the AC motors typically used in these applications.

## OFF-HIGHWAY ELECTRIFICATION INTEGRATION

Around the world, governments continue to push for cleaner emissions and improved fuel economy across all mobility sectors, including construction, agriculture, mining, and material handling — industries that Dana has supported for nearly 100 years.

To date, many major port authorities have aligned with the International Maritime Organization standards of reducing emissions by at least 50 percent. As global logistics continues to grow and push heavily toward zero-emission vehicles, Dana electrified technology is well-positioned to help our customers meet their sustainability goals and meet global regulations.

Dana's new Spicer Electrified e-hub drive replaces the diesel engine and traditional driveline. This technology leverages our core capabilities and innovation acquired through strategic acquisitions into a Dana-designed all electric solution.

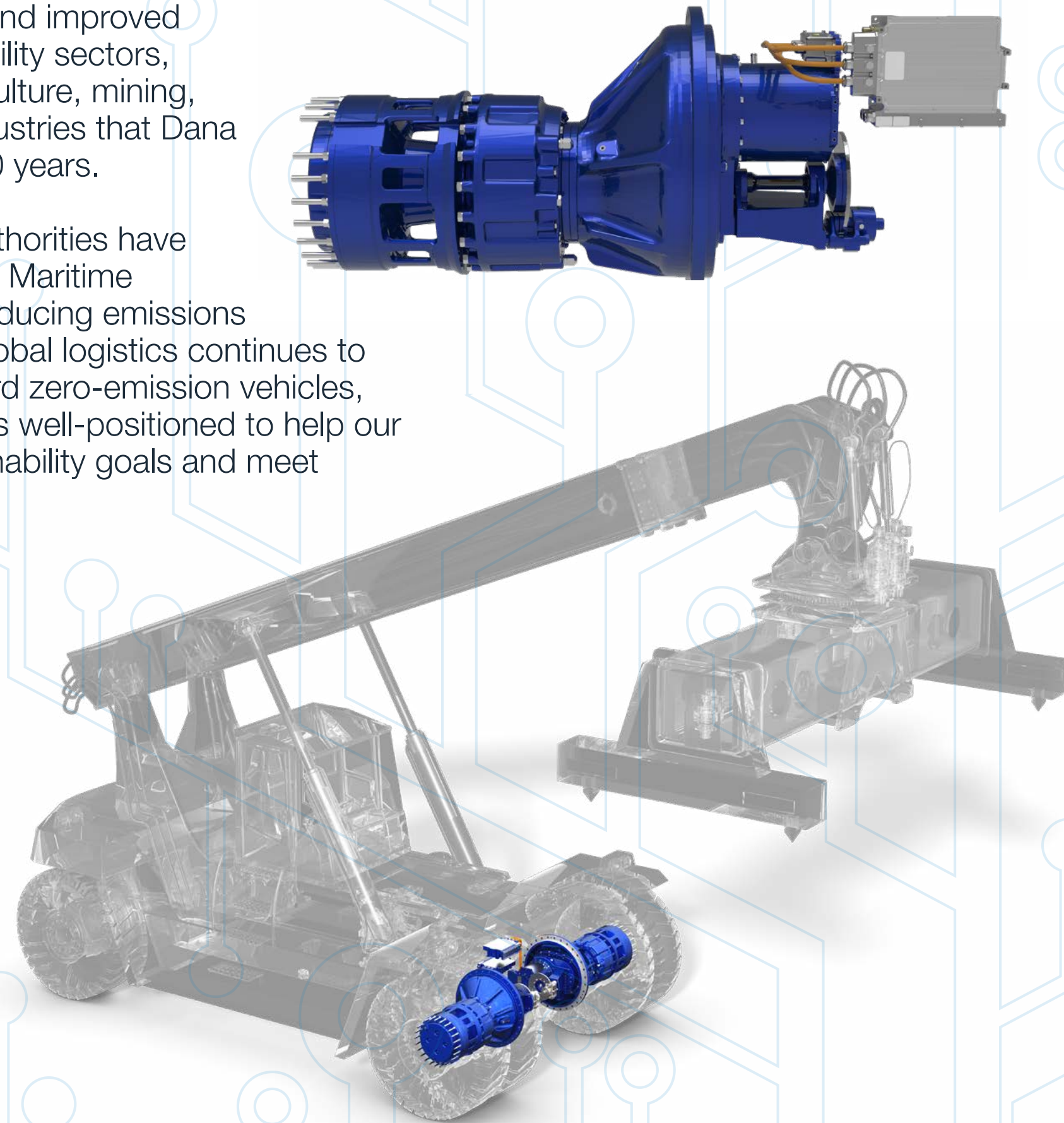

## ELECTRIC ACCESS EQUIPMENT

Dana can provide a full line of advanced technologies that deliver class-leading performance and meet ever-increasing regulations across mobility markets from small interior access equipment such as scissor lifts, and further expanding our portfolio of sustainable products.

A new electric access equipment program for JLG Industries features Dana's all-new electric Torque Hub technology combined with a state-of-the-art Dana permanent magnet AC motor and inverter.

Dana has been a long-time leader in hydraulic-driven scissor lifts, but now we are leveraging our core gear technology, combined with acquisitions to support and expand into this newly developing electric-driven scissor lift market.

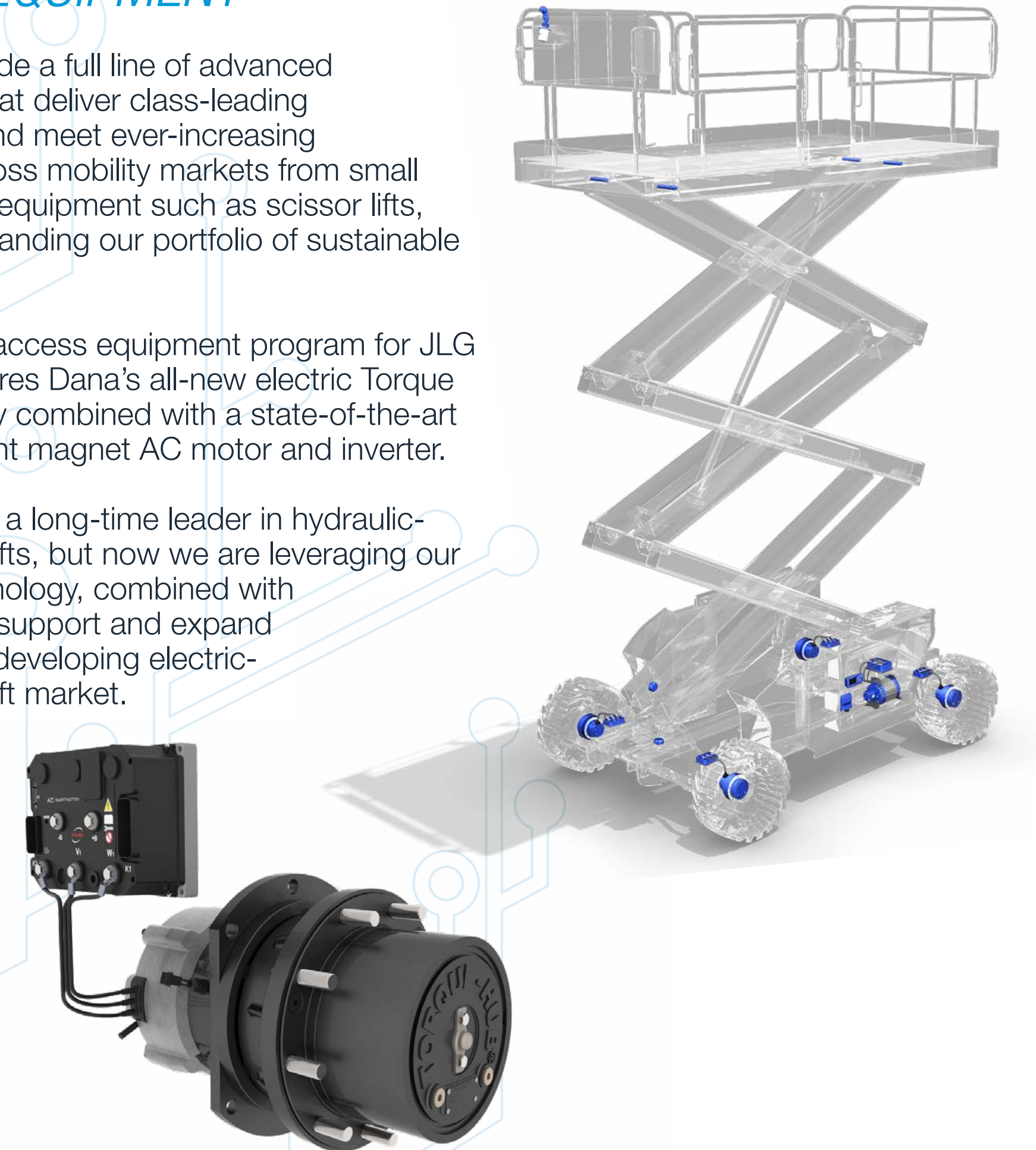

## EMPOWERING ADOPTION OF ELECTRIFICATION TECHNOLOGIES

The ideal electrified powertrain solution is one that meets the unique requirements of the vehicle, application, and customer needs.

Offering modular solutions means being able to bring together the right low- and high-voltage motors, software, controls, battery management, gearboxes, and thermal management — calibrated together to deliver the optimal, individualized electrodynamic solution.

This places a strong emphasis on complete systems expertise. Designing an efficient modular product is only one part of the equation. Being able to integrate these modular solutions into a complete system that optimizes and maximizes energy usage will be essential for customers to deliver the value demanded by the end-users.

Our ability to support complete system integration is driving growth with our customers as we find new ways to support their move toward hybrid and electric vehicle applications.

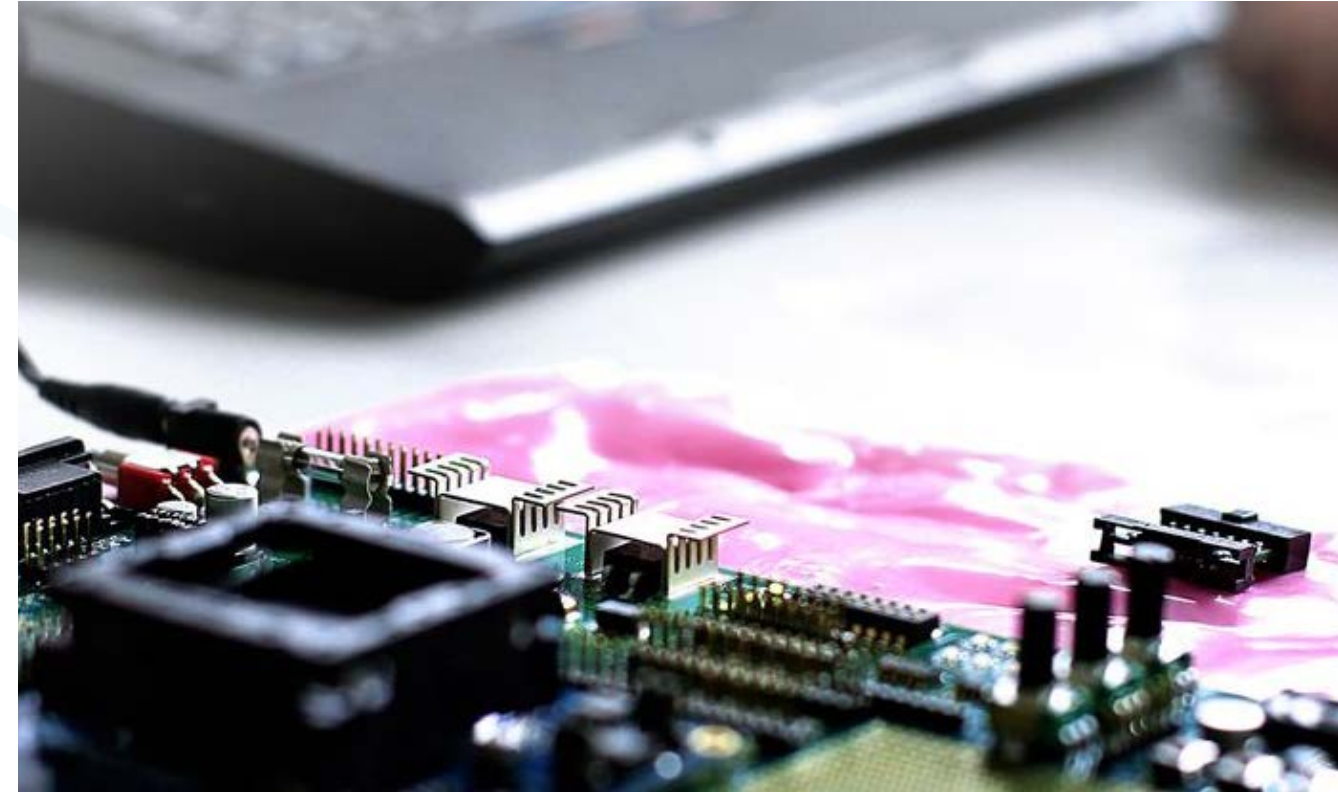

### System Integration and Strategic Acquisitions

With a focus on enhancing our in-house system integration expertise, Dana acquired Rational Motion and invested in Pi Innovo, both leaders in software, controls, integration, and engineering services for electric vehicles.

Rational Motion brings to Dana more than 10 years of experience in electric vehicle system integration, with specialized expertise in embedded software, electric powertrain testing, hardware and software in the loop, and battery simulation.

Pi Innovo, a leader in embedded software solutions and electronic control units for all mobility markets for more than 25 years, builds on Dana's robust capabilities in designing, engineering, and delivering complete vehicle integration for e-Propulsion systems.



### DAF Trucks Collaboration

DAF Trucks selected Dana to supply a complete e-Powertrain for its new DAF LF Electric, a battery electric medium-duty truck for urban and regional product distribution. Production will begin in 2021.

The e-Powertrain system, which generates, stores, and manages the energy for the vehicle, includes all electrodynamic components, embedded software and controls, an e-Power system, e-Propulsion system, and complete vehicle integration.

Our long-standing leadership in truck driveline capabilities, coupled with Dana's full e-Powertrain capabilities, provides customers, like DAF Trucks, with highly efficient solutions to support their reduced emission and total cost of ownership objectives.

## DRIVING EFFICIENCIES AND CORE CAPABILITIES

We have taken strategic steps to augment our core capabilities to support all of our customers' drivetrain and propulsion needs, regardless of the power source.

### New Technologies for Construction Equipment

We launched a new series of eight Spicer Torque-Hub® drives, expanding Dana's offering of drive and motion technologies for crawler cranes and other large-tracked vehicles. The new drives offer flexible packaging and gear ratios to meet manufacturer preferences for tracked and wheeled applications.

In addition, to support the growing construction market in China, we began manufacturing track drives for a wide range of tracked construction equipment in Yancheng, China. This added capability will decrease the supply times to original-equipment manufacturers and help them accelerate the production of equipment for domestic and global distribution.



### Drivetrain Component of the Year Award

In 2020, Dana was awarded the Drivetrain Component of the Year Award for its Spicer® TE50 powershift transmission at the 2020 Diesel Progress Summit and Awards, which recognizes commercially available drivetrain components used in a conventional powertrain application, including transmissions, powertrain components, axles, hydraulics, and wheels.

Designed for large load haul dumpers, trucks used in underground mining, and wheel loaders, the Spicer TE50 transmission increases productivity, improves reliability, and reduces operating costs for heavy-duty, high-power applications.

Its electronically modulated hydrodynamic design provides precise vehicle handling, improved fuel efficiency, smoother shifting, and optimized braking. Offered with four- or eight-speed gearboxes to optimize shifting ratios, the transmission is available with automatic lockup, which improves fuel efficiency by enabling direct drive even at low speeds.

### Yabre Basile

#### Assembly Operator

“A lot of my work is focused on the assembly and testing of motion systems — most recently gearboxes — for various stationary industrial applications. Our products are designed to extend lifespan and convey maximum power. This requires a logical approach and a sharp focus on quality as we verify all components, conduct assembly, run additional machine testing, and then sign to authenticate.”

“So, there's definitely a lot of pride in my job and a real sense of teamwork on the assembly line. One thing I truly appreciate, is the investment in me and my career through ongoing technical training, job rotation, upskilling, and mentorship.”



## DRIVING COMPONENTS FOR TOMORROW'S POWER SOURCES

In 2020, we signed a definitive agreement to purchase a portion of the thermal-management business of Modine Manufacturing Company's automotive segment. The transaction is expected to be completed in the first half of 2021 and will increase the scale of Dana's Power Technologies business unit by approximately 30 percent.

This acquisition will balance our current product portfolio by extending its offerings in chillers, water-charged air coolers, exhaust-gas recirculation, and electric-vehicle thermal technologies. More than 70 percent of the acquired product offering can be applied to hybrid- and battery-electric vehicle applications.

It will also expand Dana's manufacturing processes and supply chains, strengthen relationships with new and existing light vehicle manufacturers, and diversify the global geographic footprint of Dana's Power Technologies operations through eight manufacturing facilities across the United States, Europe, and Asia.

The transaction is expected to add approximately \$300 million in revenue based on 2019 results.

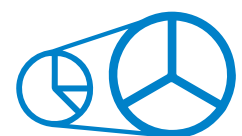

**Enhances**  
Power Technologies



**Complements**  
Customers and Geography



**Accelerates**  
Electrification



**Creates**  
Shareholder Value



### FCH Award for Fuel Cell Technology

Dana's metallic bipolar plates for fuel-cell stacks are increasing the viability of fuel-cell-powered vehicles and supporting a more eco-friendly charging infrastructure — ultimately fulfilling the company's vision of helping customers achieve their sustainability objectives throughout the entire power supply chain.

These innovative bipolar plates were recognized by the Fuel Cells and Hydrogen Joint Undertaking (FCH JU) with a 2019 FCH Award in the Best Success Story category as part of the INSPIRE project. The FCH Award recognizes outstanding projects and developments in the field of fuel cells that reduce production costs, improve manufacturing speed, develop new materials, increase performance, and demonstrate the reliability of hydrogen energy.

The INSPIRE project develops innovative stack components for fuel cells with high power densities. One of the project goals was to develop a cost-effective and competitive bipolar plate. The results of the INSPIRE project demonstrate Dana's ability to deliver a market-ready metallic bipolar plate, which is crucial for the growth of the fuel-cell market. The highly durable bipolar plate is designed to meet the extreme demands for sealing, coating, and absolute precision of the extra-fine embossing structures.

### Hossein Dadkhah

**Director**  
e-Drive Engineering



"I spend a lot of time thinking about how we can deliver innovation in a socially responsible manner. This is a big part of our vision to be the global leader in power-conveyance and energy-management solutions for the mobility industry. Shaping Dana TM4 engineering activities to develop zero-emission electrified solutions means working with hundreds of the world's leading engineers, technicians, and scientists to eliminate tailgate emissions and tackle climate change."

"These electrification components and systems — electric motors, inverters, onboard chargers and converters, and related software and controls — have a hugely positive real-world impact. This commitment to electrification development for a sustainable future and market expansion was clear from my very first day at Dana."



# Driving a Sustainable Supply Chain

Sustainability is a confluence of social, ecological, and economic considerations. Leading organizations strive to enhance their supply chains' agility and efficiency while also working to improve their sustainability — often experimenting with unique types of collaborations among suppliers and customers.

We believe that sustainability throughout the entire lifecycle of Dana products is critical to achieving our environmental objectives. Therefore, we invest in our people and ensure that our global purchasing teams engage in continuous learning and promotion of best sustainable practices through rigorous training and development programs.

This spirit of continuous improvement was recognized in 2020. Following assessment by the Chartered Institute of Procurement and Supply (CIPS) and an independent audit review, Dana was awarded a Certificate of Procurement Excellence, and became the first automotive company globally and the first company in North America to be awarded the CIPS Procurement Excellence standard.



## ABOVE AND BEYOND

We encourage our partners to create and grow their long-term environmental and social value by employing good governance practices and contributing to efforts that support the environment.

Dana believes that these extra efforts will deliver shareholder value, since greener supply chains will deliver benefits for both our business and the environment. Advantages include improving efficiency, reducing storage and treatment costs, gaining strategic insights, enhancing reputation, and building better community relations.

As such, Dana is focused on the following activities across its supply base:

- Ensuring compliance with laws and regulations and adhering to and supporting international principles for sustainable business conduct.
- Taking actions that result in better social, economic, and environmental impacts for society and our business.
- Managing and seeking to improve environmental, social, and economic performance with good governance throughout our supply chains to ensure companies also act in the interests of stakeholders, and the interests of society at large.

### WHAT'S IN A NUMBER?

**3,324**

*The number of production suppliers in more than 50 countries shipping to 141 Dana sites.*

**95%**

*The percentage of Dana strategic suppliers responding to a 2020 survey indicating they had policies addressing each of six key areas — health and safety, human rights, employee diversity, sustainability, code of conduct, and information security.*

## EVER-VIGILANT SUPPLY BASE MONITORING

We work with multiple external third-party organizations to generate strategic insights across our purchasing processes and facilitate higher levels of collaboration with suppliers. This helps to enhance the sustainability performance of our supply chain, safeguard labor practices and human rights, and generate additional evaluation criteria that assists in positively impacting the global environment.

These platforms also support the identification and mitigation of supply chain threats encompassing financial risk, reputational risk, natural and man-made disasters, geopolitical risks, and cyber risks.

We ensure that a purchasing mindset of "total systems thinking," with a focus on process and results, cascades across the entire organization. At Dana, we factor in six key considerations to drive sustainability and social responsibility in every purchasing decision made.

*"A MINDSET OF 'TOTAL SYSTEMS THINKING,' WITH A FOCUS ON PROCESS AND RESULTS, CASCADES ACROSS THE ENTIRE ORGANIZATION."*



## SUPPLIER AWARDS

### Dana's Diverse Supplier of the Year

We awarded Aztec Manufacturing Corporation, a minority-owned casting machining supplier in Michigan, United States, with our Diverse Supplier of the Year accolade. Aztec, a casting machining supplier to Dana for more than three decades and supplying five plants has steadily increased its business with Dana to greater than 6 million annually while maintaining perfect delivery and quality.

### Dana's Sustainability Supplier of the Year

We presented Gerdau, the largest Brazilian steel producer, with our Sustainability Supplier of the Year award. The company's impressive work during 2019 in the areas of recycling, water reuse, process innovation, and biodiversity conservation ensured the highest standards of care for sustainability and social responsibility.



### Eleonora Brighenti

#### Lead

Global Value Analysis / Value Engineering and Complexity Reduction

“As a mother as well as an engineer, I’ve always felt the absolute need to infuse my daily actions at work and in my private life with a higher sense of purpose. At Dana, we believe that the future is founded on ideas. As we innovate new products and motion technologies, we widen our design drivers to incorporate sustainable concepts such as recycle, reuse, and remanufacture.”

“This is a perfect synergy, integrating our products with customers’ needs and the planet’s ecosystem requirements. I’m proud to be part of a global company so engaged in this transformational growth. For ourselves, for our children, for our planet.”





# PLANET

---

# Environmental Stewardship

## NEW TECHNOLOGY AND SUSTAINABILITY COMMITTEE

*In July 2020, Dana established a standing Technology and Sustainability Committee of the Board of Directors focused on technology development and environmental stewardship.*

The new committee is responsible for assisting the Board with oversight relating to innovation, new technologies, and sustainability and social responsibility priorities. This commitment will help to leverage our resources to deliver on our technology roadmaps, and our sustainability and social responsibility priorities.

The Committee is chaired by Diarmuid O'Connell, former vice president of business development and member of the executive team at Tesla from 2006 to 2017. He is joined on the Committee by Bridget Karlin, global

chief technology officer and vice president of IBM Global Technology Services; and Raymond E. Mabus, Jr., founding principal and CEO of The Mabus Group and former U.S. Secretary of the Navy.

Key areas of focus for the Committee are:

- The strategy, implementation, and effectiveness of Dana's research and development initiatives.
- Emerging trends in science, technology, and related regulations.
- The company's strategic approach to technical talent management.
- Sustainability and social responsibility activities.



Diarmuid O'Connell



Bridget Karlin



Raymond E. Mabus, Jr.

# Tackling Climate Change

*The Earth's atmosphere is warming, faster than it probably ever has. It is clear that the scale of the climate crisis has exacerbated many of the world's biggest challenges, from poverty to wildlife extinction.*

Record temperatures across the globe are resulting in fierce hurricanes, droughts, and floods, forcing natural environments to change more quickly than wildlife or people can adapt.

We understand how important it is for organizations to play a leading role in achieving a sustainable future. For Dana, this means seeking solutions and working smarter as we support customers and the development of our communities — while always seeking to minimize our impact on the environment.

We believe that a policy framework underpinning long-term investment and planning is needed, and that we have a responsibility to show solidarity and sustain this goal on the world stage.

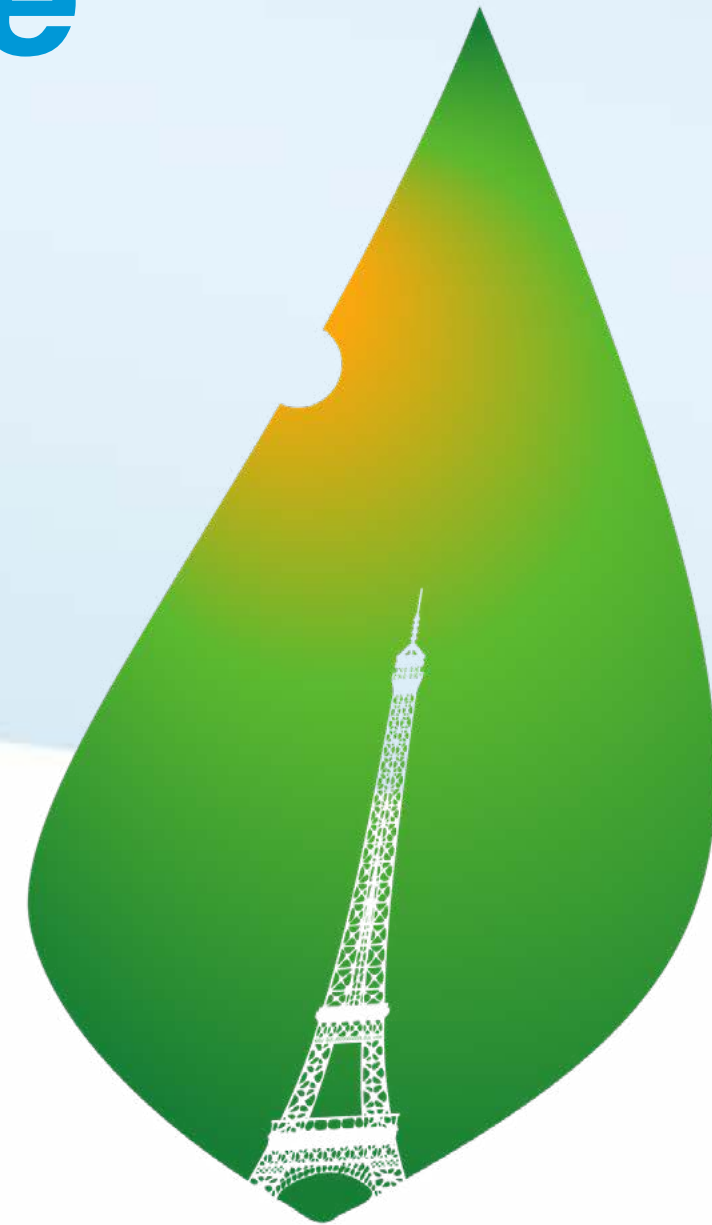

**PARIS2015**  
UN CLIMATE CHANGE CONFERENCE  
**COP21·CMP11**

## PARIS CLIMATE AGREEMENT

As such, in 2019, Dana Chairman and CEO Jim Kamsickas, along with the CEOs of 75 other companies, endorsed an open letter to show the collective support of the Paris Climate Agreement.

The Paris Climate Agreement sets out a global framework to avoid dangerous climate change by limiting global warming to below 2°C and pursuing endeavors to limit it to 1.5°C. It also aims to strengthen countries' abilities to deal with the impacts of climate change and support them in their efforts.

Our support for the Paris Climate Agreement means acting now to curb the effects of climate change through our electrified product portfolio, continued implementation of energy-efficiency improvements across our manufacturing operations, participation in on-site and off-site renewable energy projects, and our investment in forward-thinking, utility-scale renewable energy projects that are transforming energy production sourcing.

# Thinking Big

## REDUCING GHG EMISSIONS MORE THAN 50% BY 2035

We understand that accelerated, focused action is necessary to tackle climate change. Therefore, to ensure transparency and publicly commit to do our part in transitioning to a low-carbon future, we have publicly stated our targeted Greenhouse Gas (GHG) reduction totals and completion date.

In Q4 2020, Dana committed to reduce its total annual greenhouse gas emissions by at least half before the end of 2035, representing a reduction of more than 300,000 metric tons of carbon dioxide emissions annually. This is equivalent to the **annual energy production of 65 wind turbines.**

### Our Sustainability Journey

To reach this aggressive emission reduction goal, we are taking a number of sustainability actions — including:

- 1. Reducing our overall energy consumption and increasing the efficiency of our processes:** Over the last five years, Dana has completed more than 500 projects that take aim at reducing our environmental footprint. Upcoming projects include upgrading to LED lighting, optimizing compressed air systems, and replacing motors and pumps with higher-efficiency units.
- 2. Sourcing additional renewable energy:** Dana is currently sourcing renewable energy through solar arrays at several locations globally and will be implementing further use of renewable energy, such as wind or solar to utilize clean energy sources to reduce GHG emissions.
- 3. Leveraging Renewable Energy Credits (RECs):** RECs represent proof that one megawatt-hour of energy was generated from a renewable source and sent to the grid and helps offset emissions.

## NEW CHIEF SUSTAINABILITY OFFICER

To champion our sustainability and social responsibility goals, we announced that — in addition to his roles as senior vice president, general counsel, board secretary, and chief compliance officer — Doug Liedberg has been promoted to the expanded role of chief compliance and sustainability officer.

In this position, Doug leads our corporate responsibility efforts, ensuring that we maintain our key focus on driving sustainability and social responsibility initiatives across the organization. He will continue to chair our Sustainability and Social Responsibility Leadership Council, which meets regularly and helps to implement policies, procedures, and disclosure reports.



Doug Liedberg

“Dana people want to work towards something that matters. This means understanding not only their role within the organization, but Dana’s wider contributions to society. This higher purpose guides our commitment to developing products that reimagine the future of sustainable drivetrain and e-Propulsion systems. We focus on always conducting business with the right values, putting integrity at the heart of everything we do, and engaging with and giving back to the communities where we live and work,” said Doug Liedberg.

## DANA SIGNS LONG-TERM RENEWABLE ENERGY AGREEMENT



### Long-term wind electricity agreement

In support of our climate change commitments, Dana signed a long-term agreement to add renewable electricity to the grid beginning in 2022.



### Source 300,000 megawatt-hours

Contribute to renewable energy by providing 300,000 megawatt-hours annually of additional wind energy to the electricity grid.



### Reduce U.S. GHG emissions by 90%

Secure renewable energy credits to reduce our current annual Greenhouse Gas (GHG) emissions from electricity in the U.S. by approximately 90%.



### ~150,000 metric tons of GHG removed annually

Remove approximately 150,000 metric tons of GHG annually.

"Dana to reduce total annual GHG emissions by more than 50% by 2035 — a reduction of 300,000+ metric tons of GHG annually."

Jim Kamsickas, Chairman and CEO  
October 20, 2020



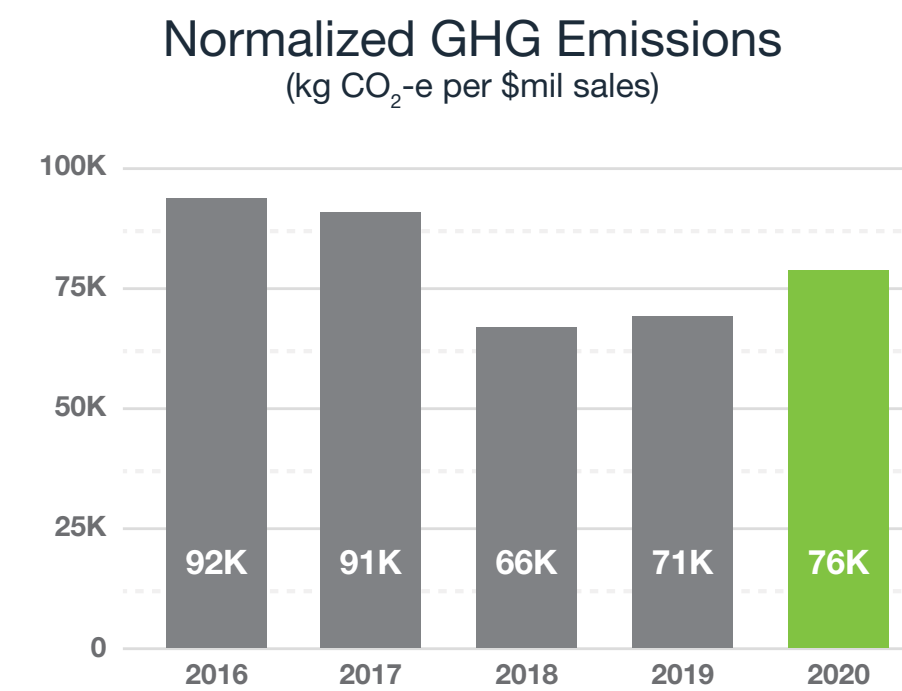
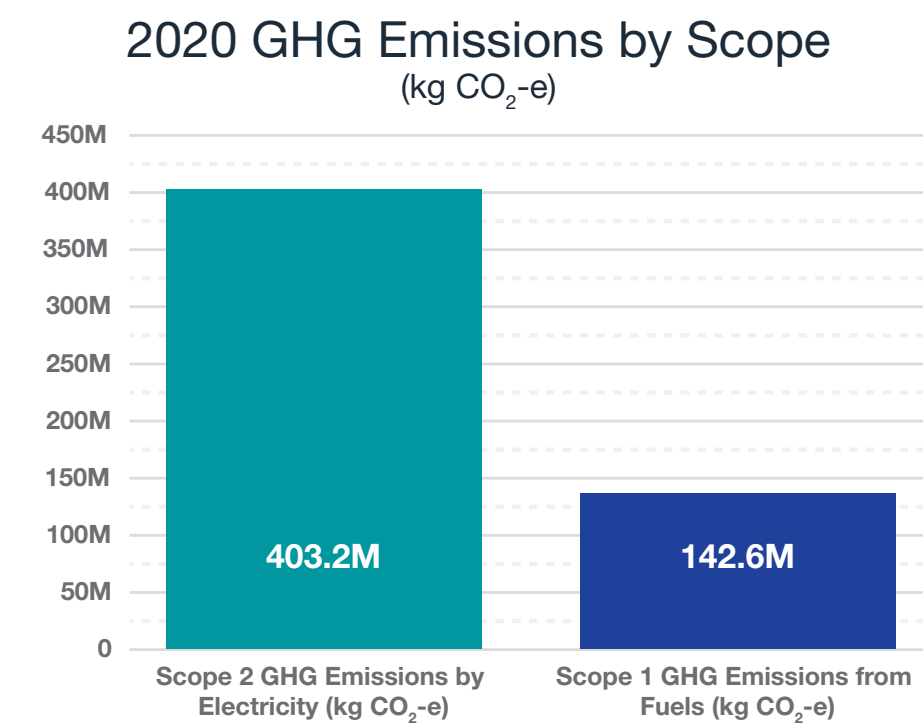
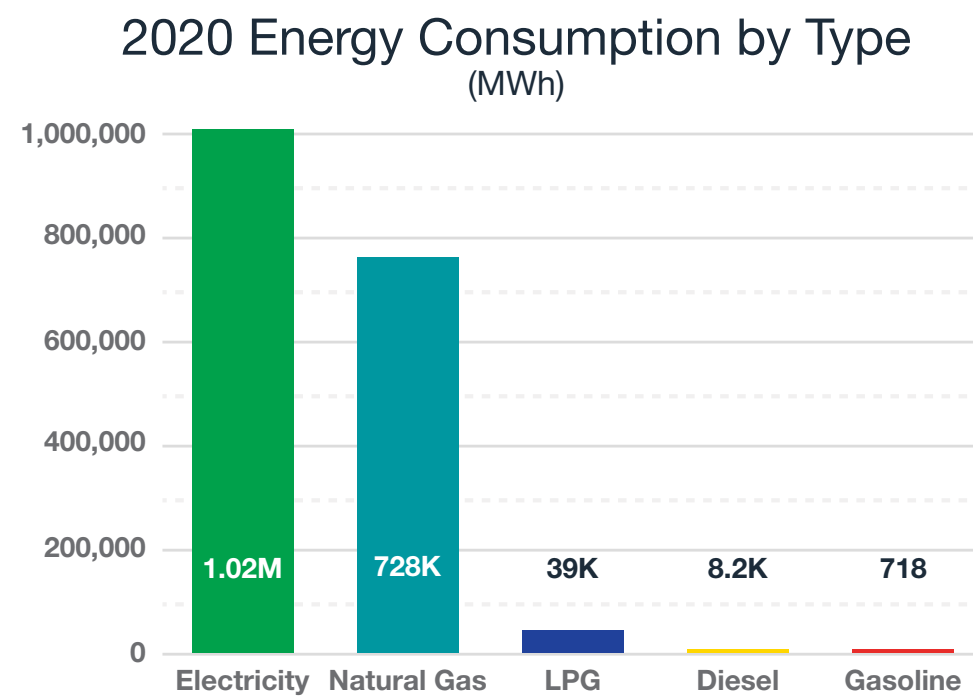
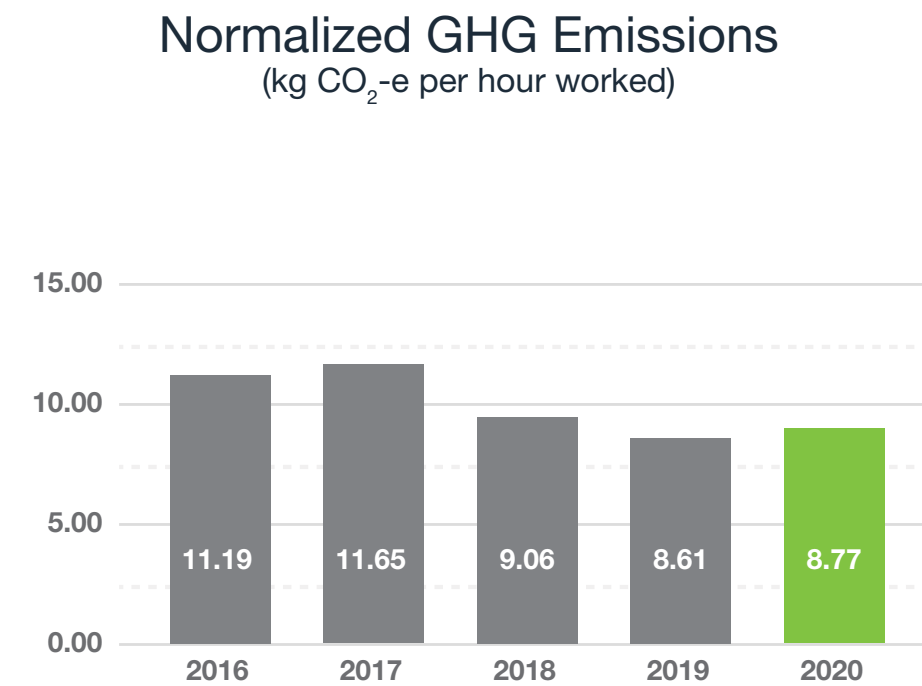
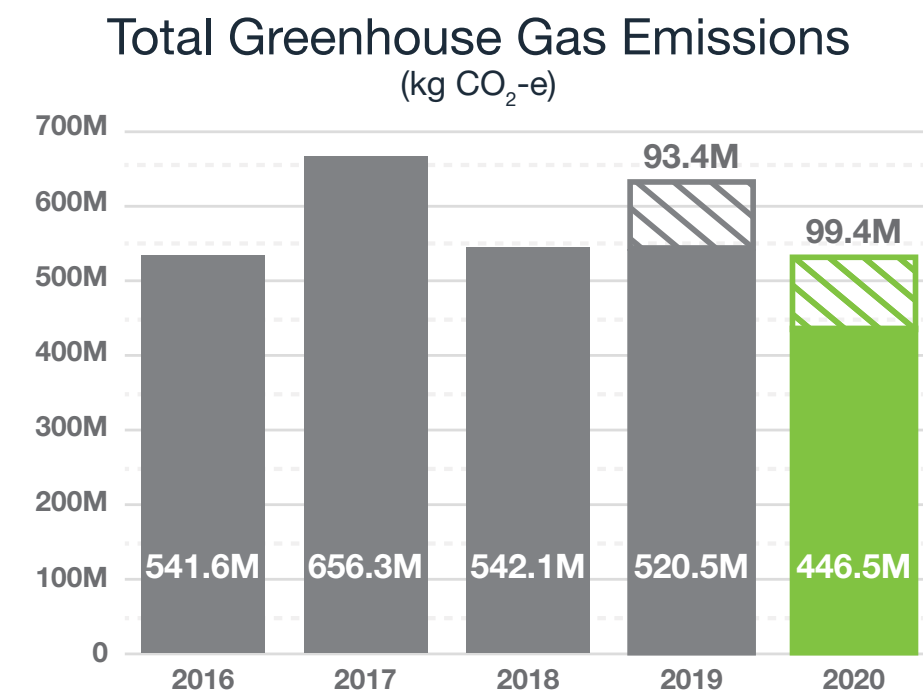
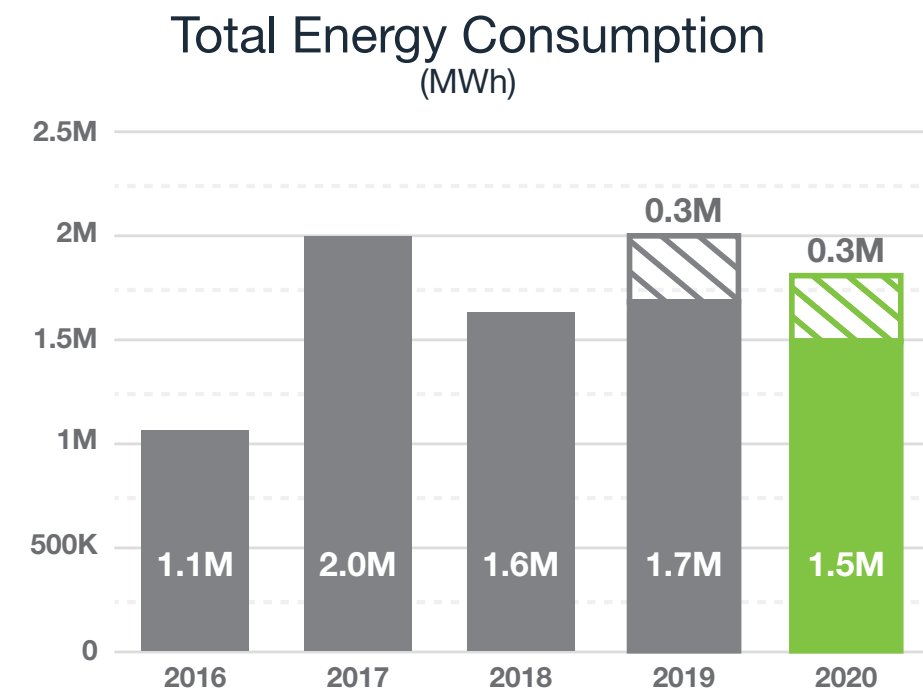

Diagonal lines on the charts indicate the additional impact on total energy consumption and total greenhouse gas emissions as a result of growth through acquired businesses and new greenfield locations.

## Greg Morris

### Head of Global Sustainability



“Regardless of where Dana’s 38,000 colleagues live, we all have one home. Each day presents a new opportunity to “do good” — for our people, our company, our customers, and our planet. Our focus on safety, pursuit of quality, shift to electrified products, commitment to reduce GHGs, and participation in renewable wind energy projects shapes and fuels our passion to find a better way.”

“This balanced approach informs how we interact with our people, develop products, and treat our planet and signals our higher purpose to the world. I am honored to work alongside the great women and men who share this enthusiasm for leading Dana into our sustainable future.”



## NEW SOLAR ARRAY POWERING TOLEDO OPERATION

*In 2020, we finalized a collaborative community project capitalizing on the benefits of renewable energy while also making significant economic impacts on the residential neighborhoods surrounding our 300,000-square foot axle assembly operation located at Toledo's Overland Industrial Park, Ohio, United States.*

The 2.5-Megawatt solar array generates enough power to reduce the amount of carbon dioxide by more than 1,600 tons — the equivalent of removing 300 cars from the roadways every year.

Through our partnership with the Greater Toledo Community Foundation, the nonprofit entity that owns the solar field in conjunction with the Toledo-Lucas County Port Authority, we are able to generate a revenue stream through the purchase of renewable energy by Dana — with the proceeds being reinvested in the surrounding neighborhood through grants to local nonprofits.

Several companies have provided support for the project through in-kind donations and/or reduced rates, including First Solar, Yaskawa Solectria Solar, GEM Energy, JDRM Engineering, Kokosing Construction, Mannik & Smith Group, and TTL Associates, Inc. Dana has committed to purchasing all energy produced from the solar array.

*“WE HAVE ACCELERATED INVESTMENTS NEEDED FOR A SUSTAINABLE, LOW CARBON FUTURE BY SETTING CLEAR GOALS THAT ENABLE LONG-TERM PLANNING AND ENCOURAGE INNOVATION.”*



Toledo Driveline solar array, Ohio, United States

## EXPANDED USE OF SOLAR ARRAYS INCLUDING LOCATIONS IN INDIA AND ITALY



Chakan, India



Jodalli, India



Pantnagar, India



Sanand, India



Satara, India



Bari, Italy



Rivoli, Italy



Sommariva, Italy

## NEW SUSTAINABLE MOBILITY CENTER



Sustainable Mobility Center, Maumee, Ohio, United States

Recognizing the increasing demand for advanced electrified solutions, Dana is opening a new Sustainable Mobility Center at its World Headquarters campus in Maumee, Ohio, United States. This state-of-the-art facility will focus on the development electrified products for each of Dana’s end-markets and serve as a manufacturing site for motors for our e-Propulsion systems.

The facility will also offer a dynamic customer-experience center, showcasing Dana’s electrified mobility technologies and systems engineering, while providing a location to educate and generate awareness around future mobility and all aspects of alternative propulsion powertrains.

In 2020, Dana commenced the process of Leadership in Energy and Environmental Design (LEED) certification for the facility. Participating facilities earn points for implementing various green building initiatives such as incorporating renewable energy assets as part of the facility’s energy mix, reusing rainwater, and providing designated spaces for public transportation and electric vehicles. We will conclude the certification process for the new facility before the end of the year.



Visit [usgbc.org](https://usgbc.org) to learn more about LEED Certification

### Carl Ajuziem

**Associate**  
CAD Designer



“I’ve recently been designing 3D components of an electric axle for a medium-duty vehicle. This involves a lot of collaboration with the advanced engineering group, bouncing ideas off each other, and working closely with customers to understand performance needs.”

“My role can also include challenges like fitting a hydraulic pump and electric motor into a tight packaging space. You can have all the ideas in the world, but it’s only until you model it in CAD that you really see how it all comes together. During my five years at Dana, I’ve always felt the backing to showcase my skills and what I have to offer. I’m happy to help shape technologies driving a more sustainable future.”

## THE IMPORTANCE OF CONSERVING WATER

Access to water and sanitation is recognized as a human right, reflecting the fundamental nature of these basics in every person's life. Lack of access to safe, sufficient, and affordable water and hygiene facilities has a detrimental effect on the health and prosperity of billions of people and has significant consequences for the realization of other human rights.

While our manufacturing operations are not as water intensive as those of other industries, we recognize the far-reaching economic, social, and environmental implications that water scarcity may have in the future — and have taken steps to reduce our consumption.

We continue to implement conservation strategies.

- Remove / reduce water use in our operations, where feasible.
- Explore water-treatment technologies and introduce processes to re-use water.
- Train employees about water resources to raise their awareness of the issue.



Rain water harvesting at Dana Sanand, India



Cooling tower at Fort Wayne, Indiana, United States

### Total Water Consumption (m<sup>3</sup>)

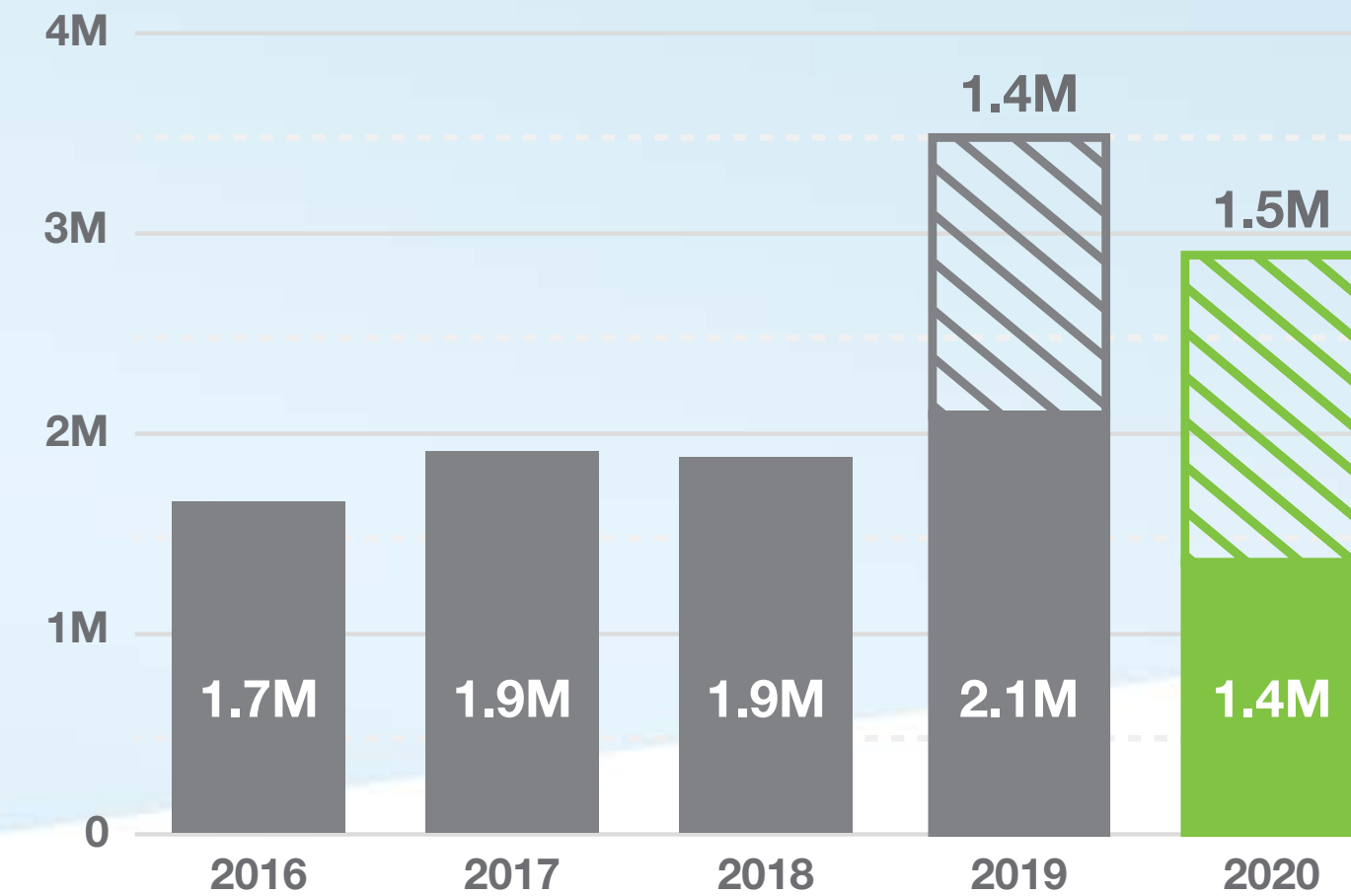

Diagonal lines on the chart indicates the additional impact on total water consumption as a result of growth through acquired businesses and new greenfield locations.

### Total Normalized Water Consumption (m<sup>3</sup> per hour worked)

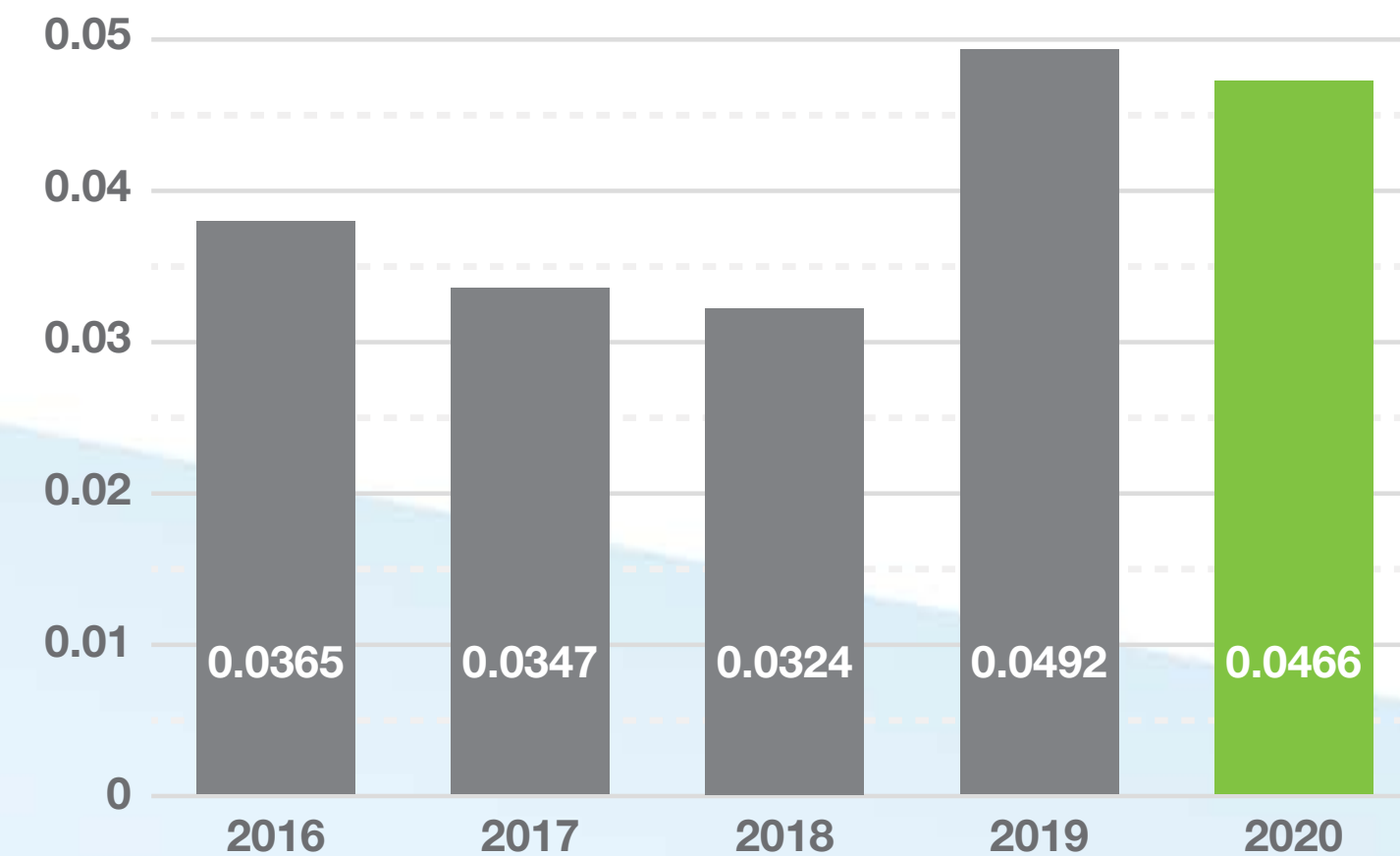

## GOING ABOVE AND BEYOND

Our commitment to compliance with all applicable environmental requirements worldwide is only our initial step in taking action. We view adherence to compliance obligations as a minimum requirement. We go beyond compliance to make a positive difference regarding the environmental impact of our activities.

Where regulations do not exist, we operate responsibly by adopting best practices and pursuing innovation. These processes are based on our own operational knowledge and experience which enhances our focus on our people, products, and planet.



Waste from Dana cafeterias at facilities in Campinas and Jundiaí, Brazil, is composted preventing more than **60 tons per year** ending up in the country's landfills. This effort from plants where 1,500 Dana people work helps to transform organic matter such as food waste, paper, and vegetation in a nutrient-rich fertilizer as well as reducing soil pollution.

## WASTE MINIMIZATION

We continually assess our waste streams and waste-handling operations by identifying high-value materials for reuse and recycling, as well as ways to eliminate or minimize what we send to landfill.

We recognize the potential negative societal and environmental impacts of improper handling and disposal of hazardous waste. Accordingly, we have initiatives in place to ensure proper disposal and to meet all applicable regulatory handling and disposal requirements.

In Hungary, our Győr facility rolled-out a wastewater treatment project resulting in **1,400 cubic meters** (369,841 gallons) of water saved as a result of improvements made to the phosphate line wastewater treatment process.

### 2020 Non-Hazardous Waste by Treatment Method (kg)

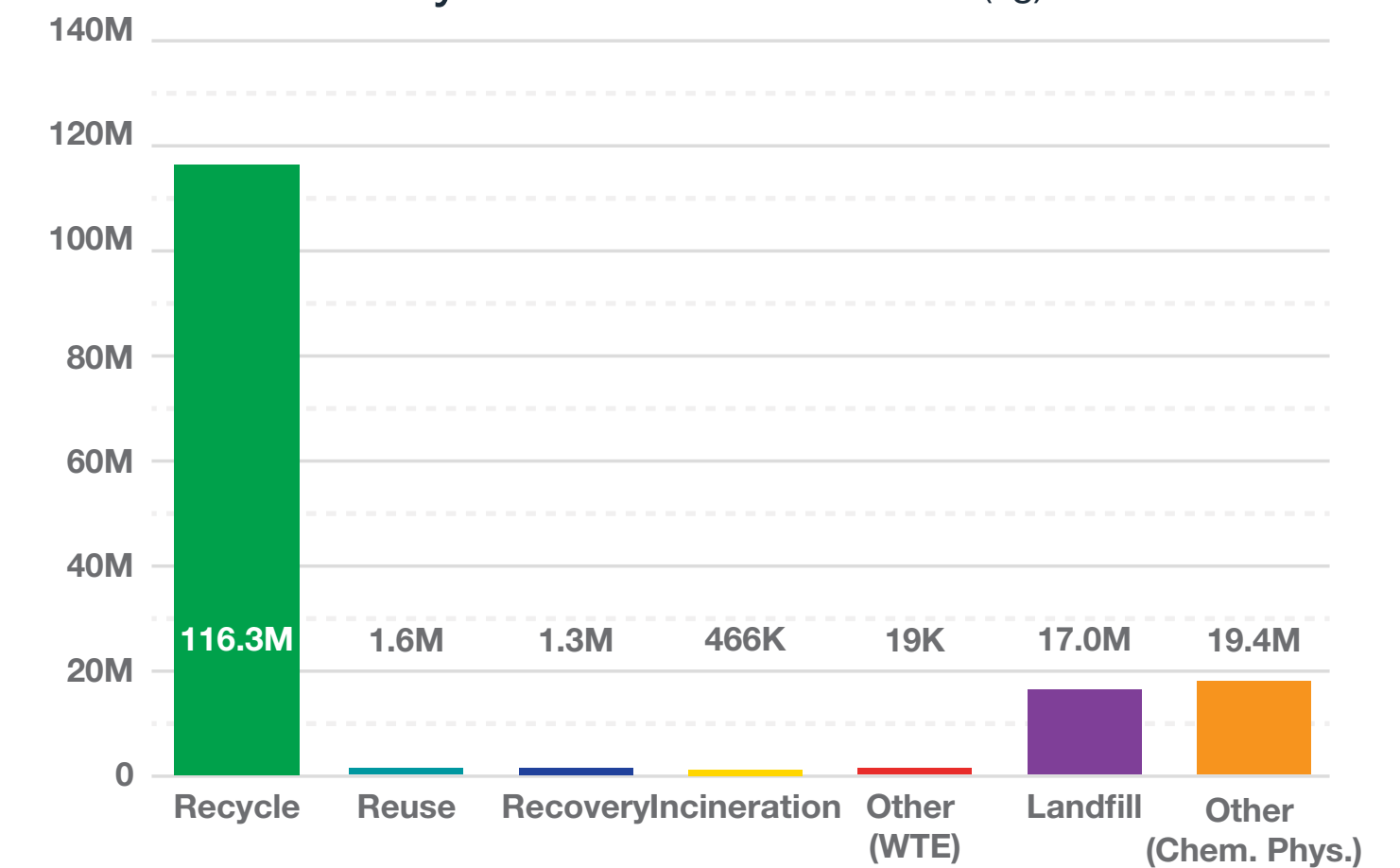

Our Tlalnepantla facility in Mexico implemented a wastewater treatment project that resulted in **1,900 cubic meters** (501,927 gallons) of water saved by replacing an older feed tank for their ultrafiltration system wastewater treatment system.

## ENVIRONMENTAL MANAGEMENT SYSTEM

Dana's Environmental Management System (EMS) evaluates social and financial impacts in addition to environmental effects to ensure that we are considering sustainability for all stakeholders, including customers, shareholders, employees, suppliers, and governmental agencies. As the cornerstone of our EMS, Dana's Environmental Policy commits to:



- **Efficient natural resource consumption and pollution prevention:** Our operations conduct focused workshops to map manufacturing processes; assess inputs into the processes in terms of environmental solids, water, energy, air emissions, and toxins (chemicals); and challenge existing processes to remove, reduce, reuse, and / or recycle the process outputs to remove costs and minimize the associated environmental footprint.
- **Compliance with applicable rules and regulations:** Our facilities undergo a rigorous internal environmental compliance assessment to review federal, state, provincial, and local requirements, as well as a robust internal corrective action system to remediate any deficiencies identified within the assessment.
- **Conformance to customer and company expectations:** Our manufacturing and assembly operations are required to obtain and maintain a certificated ISO 14001 EMS that includes pertinent EMS risk / opportunity assessments, operational control documentation, awareness and training, internal audits, management review, and external verification assessment.

### Air Quality

We are also committed to reducing air emissions, including carbon monoxide, nitrogen oxides, particulate matter, sulfur oxides, volatile organic compounds, and hazardous air pollutants.

To help improve air quality, our facilities comply with federal, state, provincial, city, county, and district requirements. Third-party environmental professionals review and audit our environmental programs for compliance as necessary. These audits include a multifaceted inspection of agency reporting, emissions records, training records, and other work practices.

*AS OF DECEMBER 31, 2020,  
97% OF DANA'S MANUFACTURING  
SITES WERE CERTIFIED TO THE  
ISO 14001 ENVIRONMENTAL  
MANAGEMENT STANDARD.*

## 2020 SUSTAINABILITY AWARD

Dana's Cardanes facility in Querétaro, México, was selected as the 2020 Sustainability Award winner. This award goes to the facility that demonstrates outstanding leadership and results in reducing overall energy use.

The Cardanes team developed and installed a machine energy optimization system designed to eliminate the consumption of electricity during machine idle time and reduce the consumption of energy during high-cost, peak periods.

The machine energy optimization system was installed and programmed with defined parameters for hibernation mode after five minutes of inactivity. This eliminated the use of energy during lunch breaks, shift changes, training events, and other times a machine would be idle.

The reduction of electricity consumption in the plant is monitored using software developed by Cardanes employees. These efforts have resulted in their overall energy reduction of more than 8.5M kWh annually, or nearly 4,000-metric tons of greenhouse gas emissions each year, with significant energy cost savings.

In 2021, the facility is evaluating additional equipment for the energy optimization program to drive even further savings. These innovative ideas implemented by the Cardanes team demonstrate best practices that can be incorporated into other facilities to lower Dana's overall carbon footprint and help to achieve our aggressive sustainability goals.



# SOME EXAMPLES OF OUR TEAMS' SUSTAINABLE COMMITMENTS IN ACTION.

## Global

Staff vehicles due for lease renewal in 2021 are scheduled to be converted to electric / hybrid vehicles.

## United States and Mexico

We implemented efficiency programs around chemical consumption and recycling at our facilities, driving value across our operations and ensuring continued exceptional environmental management.

## Paris, Tennessee, United States

We used a campus-wide study to identify inefficiencies in our compressed air use, delivering annual energy savings of 500,000 kWh.

## Querétaro, Mexico

We eliminated non-value consumption of electricity during machine idle time and reduced energy use during high-cost, peak periods, delivering annual energy savings of 8,500,000 kWh. We also switched to reusable plastic containers for internal material handling in production lines, eliminating 19,600 kg of waste cardboard and wood annually.

## Mount Forest, Ontario, Canada

We invested in a study to identify inefficiencies in compressed air, delivering energy savings of 49,000 kWh.

## Pottstown, Pennsylvania, United States

We installed variable frequency drive on electric motors, which reduces electricity demand during equipment startup and eases the strain on motor and wiring components, delivering annual energy savings of 150,000 kWh.

## Lafayette, Indiana, United States

We reduced wood product usage by 220 pounds (100 kg) per month by deploying reusable plastic as well as reducing electricity and air consumption in our testing process. In 2020, we also began a tree planting program to promote sustainability.

## Slidell, Louisiana, United States

We drive sustainability by repairing gearboxes to meet, and in many cases exceed, original design life.

## Jundiaí, Brazil

We replaced printed paper maintenance work orders with electronic work orders, eliminating 143 kg of paper waste annually.



# SOME EXAMPLES OF OUR TEAMS' SUSTAINABLE COMMITMENTS IN ACTION.

## Essen, Germany

Eighty percent of Dana's Off-Highway pool cars are now hybrid.

## Villefranche, France

We enhanced the cleaning process for painting equipment, reducing the annual volume of used solvent and used paint by 1,500 kg per year.

## Győr, Hungary

We eliminated the use of 5,400 wooden packaging racks by switching to recyclable racks when shipping axles.

## Sanand, India

We harvest rainwater, use on-site solar power, and planted more than 15,000 trees on-site to demonstrate our ongoing sustainability commitment.

## Pune, India

We changed our hydraulic oil sump cooling equipment from a cooling tower to an existing chiller system, delivering annual energy savings of 210,000 kWh / annual water savings of 240 cubic meters.

## Rayong, Thailand

We installed LED lighting across the facility, delivering annual energy savings of 41,000 kWh.

## Bangkok, Thailand

We were awarded the 3R Gold Medal from the Ministry of Industry for sustainability and scrap reduction.

# Community Engagement

*We are proud to contribute to and partner with organizations that are making a difference in our neighborhoods and believe that it is important for our communities to know who we are and what we are about.*

We celebrate those teams and individuals who come together to build and nurture causes close to their heart and make a positive impact in the communities where we do business and call home.

Supporting the communities that we serve is an important part of Dana's values. We believe that assisting our communities' needs helps to build opportunities for people, and we continually provide outreach in many different forms.

These include mentoring students in under-represented schools, donating food to local food banks, cleaning roads, cleaning trails in local parks, and partnering with other organizations to deliver wi-fi for students during the COVID-19 pandemic. Here are just a handful of examples of how our people around the world made a difference.

*"WE BELIEVE THAT IT IS IMPORTANT FOR OUR COMMUNITIES TO KNOW WHO WE ARE AND WHAT WE ARE ABOUT."*





## MARATHON CLASSIC PRESENTED BY DANA SUPPORTS LOCAL CHILDREN CHARITIES

The 2020 Marathon Classic Presented by Dana, a Ladies Professional Golf Association tournament, took place near Dana's World Headquarters at Highland Meadows Golf Club in Sylvania, Ohio, United States.

While the tournament features the world's greatest female golfers, the real stars every year are the charities supported by this iconic tournament. Since 1984, the Marathon Classic has raised more than \$12 million for 185 children's charities in northwest Ohio and southeast Michigan, United States.

Recipients of charitable grants in 2020 included the Ronald McDonald House Charities, YMCA, Girls on the Run, Connecting Kids to Meals, and Big Brothers, Big Sisters, as well as 20 other deserving organizations.

The 2021 edition of the tournament is slated for July 8-11 and is expected to raise more than \$600,000 for children's charities this year alone.



## DANA CHARITABLE FOUNDATION

Founded in 1956, the Dana Charitable Foundation is a U.S.-based philanthropic organization that makes grants to non-profit organizations that support education, health and human services, arts and culture, and neighborhood reinvestment.

The Dana Charitable Foundation also matches employee and retiree giving to accredited educational institutions at 50 cents for every dollar contributed, up to a maximum gift of \$5,000 per person.

In addition to the grants made from the Dana Charitable Foundation to support the communities where Dana operates, the company provides numerous opportunities throughout the year for its employees to volunteer in meaningful ways to support their local communities.



*Charitable  
Foundation*

## DANA SPICER THAILAND LADKRABANG COMES TOGETHER TO SUPPORT THEIR COMMUNITY

The team at Dana's Spicer Thailand Ladkrabang plant showed support for their community by helping to renovate an old nursery building, giving it a much-needed makeover. They also collected essentials for the Suthapoj Nursery School in Bangkok.



## DANA HUNGARY HONORED AS COMPANY OF THE YEAR

Dana Hungary was awarded Company of the Year 2020 by local government officials, recognizing outstanding performance throughout the year and the positive impacts made on the region's communities and economic development.

The founder of Hungary's regional Prestige Awards expressed the importance of investing and growing under today's challenging economic circumstances. He also highlighted the outstanding job of the Dana team despite economic and virus-related challenges.

To be recognized in the category of Company of the Year is a great honor for Dana Hungary, which includes 1,000 engaged employees representing all four of Dana's businesses operating as One Dana.

### Elena Marino

**Senior Manager**  
Environmental, Health,  
and Safety



“Create the world you want to live in” is an ideal everyone should follow. During my time at Dana, I’ve had the great pleasure to make some life-long friends and work in a team that always goes the distance for each other.”

“I saw this especially during the year as we came together to protect our people and our business as the pandemic struck. But this sense of teamwork and continuous improvement has always run through the company. Whether it’s a lens of safety or sustainability, there’s a passion for connecting with colleagues and finding the best way to develop our systems and processes.”

## PLAYHOUSES FOR LOCAL FAMILIES

In November 2020, a team from Dana World Headquarters, Maumee, Ohio, came together to build playhouses in support of the Maumee Valley Habitat for Humanity.

Maumee Valley Habitat for Humanity's Project Playhouse offers a fun, dynamic, meaningful construction / team-building experience for any group that wants to partner with Habitat for Humanity but, amidst a pandemic, cannot commit to a traditional full-day home build project. Smaller projects such as Project Playhouse take place year-round and can be brought to a sponsor's location.



## BIODIVERSITY DRIVE IN INDIA

Conservation researchers often highlight that species are to ecosystems what rivets are to a plane's wing. Losing one might not be a disaster, but each loss adds to the likelihood of a serious problem.

To this end, Dana's team in India during 2020 supported communities by conserving the biodiversity of both rural and urban areas to promote clean air, water, and healthy soil. One of the major activities under this umbrella is the rejuvenation of ponds to promote and conserve ecosystems.

Around the world, pond habitats are disappearing at an alarming rate as cities expand. Dana's team in India undertook the significant task of deepening five ponds located in the vicinity of villages near Greater Noida, Kolhapur, and Sanand, with a combined water recharge capacity equivalent to providing an annual water supply to over 900 families.

Deepening these ponds has resulted in multiple benefits including improving irrigation for the five local villages near the project and preventing soil erosion; increasing the ground water level which raises the water level in the wells and the availability of clean, drinkable water; and enhancing the fertility of the agricultural land in the region and supporting biodiversity.

## Stephanie Kleinschmidt

**Manager**  
Global Travel and  
Indirect Commodity



"This has been a year quite unlike any other. An initial request in January 2020 to help procure face masks for two Dana plants accelerated into months of complex logistics, sourcing millions of masks and other PPE — gloves, thermometers, hand sanitizer, face shields, safety goggles, gowns, and thermal body scanners — for frontline employees at sites around the world."

"Whether negotiating contracts, coordinating delivery, or organizing food drives for those feeling the effects of the pandemic the most — the Dana spirit of generosity and "can-do" attitude shone through. It blew me away."

## DANA'S REGGIO EMILIA TEAM BOOSTS LOCAL COMMUNITY

In September 2020, the team in Reggio Emilia, Italy, sponsored a local community event called “Chiaridiluna,” linked to the summer event series Reggio per Reggio.

The purpose of the event was to help support local businesses and reinvigorate the town’s social and business life. The event included entertainment and leisure activities where members of the community could safely come together to help bring new life to the historical town center as well as smiles back to the faces of those within the community.

## DANA WORLD HEADQUARTERS HOSTS DRIVE-UP FOOD DONATION

In June 2020, Dana World Headquarters partnered with Food for Thought to collect more than 1,000 pounds of food to help serve those in need in the Toledo-area community.

Dana volunteers, including Chairman and CEO Jim Kamsickas, unloaded food and supplies donated by employees, retirees, and others in the neighborhood. To ensure the safety of everyone, the Dana team set up a drive-through donation station where those participating could pull up so volunteers could unload food and supplies all while social distancing.



## TEAMS ACROSS INDIA SUPPORT COMMUNITIES

As COVID-19 continued its impact around the world, Dana teams in India did their part to support their communities by helping those most in need.

Dana donated 20,000 face masks to the police commissioner's office in Pune. Their generosity helped local police personnel who are on the frontlines remain safe as they worked to serve and protect their communities.

People at our Chakan plant distributed more than 200 grocery kits to the Kuruli village, providing much-needed relief to families who had been greatly impacted by the lockdown.

Dana's Satara facility, with support from the SNS Foundation, distributed approximately 200 packets of essential food items such as rice, dal, sugar, tea, wheat flour, spices, and salt to local families and migrant students. In Jodalli, with the help of the SNS Foundation, Dana distributed face masks among the villages in the surrounding areas.



### Purushottam Jangir

**General Manager**  
Human Resources and  
Corporate Social  
Responsibility, India



“My responsibilities entail managing Dana talent across three locations in India as well as coordinating corporate social responsibility initiatives for our entire India presence, which covers more than 6,000 employees at 18 locations.”

“For some time now, we have been organizing family healthcare centers, vocational training and education, improving village infrastructure, and sustainability and disaster management projects. The pandemic has brought our commitment into even sharper focus. It's hard to express the pride I have in our people when I see how much joy is derived from supporting local communities. It comes from both a sense of belonging but also from working for a business that truly takes an interest in wider social issues.”

## DANA BRAZIL DONATES FOOD AND HYGIENE KITS

As part of the food drive launched throughout operations in Brazil in May, the Dana Brazil team collected more than 18,500 pounds of non-perishable food and 350 hygiene kits. The items were delivered to the city hall food banks of Campinas, Gravataí, Jundiaí, and Sorocaba to be distributed to families in need across these communities.

Since the beginning of the pandemic, the Dana team has carried out numerous initiatives in Brazil, including the delivery of more than 6,500 masks to the families of employees, as well as lunchboxes for neighboring communities. More than 100 donors across the Brazilian operations participated in a blood drive.



## DANA DELIVERS PPE AROUND THE GLOBE

Since the outset of the pandemic, our Purchasing and Environmental Health and Safety teams from Dana World Headquarters, Maumee, Ohio, United States; Dana Arco, Italy; Dana Gravatai, Brazil; and Dana Wuxi, China; collaborated to procure and distribute personal protective equipment for employees and first responders around the world.

The team successfully sourced millions of masks, gloves, thermometers, hand sanitizer, face shields, safety goggles, gowns, and thermal body scanners for Dana globally. This involved leveraging our global supplier relationships to identify supply and expedite delivery for organizations with frontline employees.



## DANA LAFAYETTE DONATES CARE PACKAGES TO LOCAL HOSPITALS

In April 2020, the Dana team in Lafayette, Indiana, United States, responded to a request from the director of nutrition services at the Tippecanoe School Corporation about a need to help children in their area who rely on school lunches.

With schools being closed, the Lafayette team came together to assemble and distribute care packages to families in need. The facility also donated 110 care packages for two area hospitals.







# GOVERNANCE

---



# Corporate Culture Matters

Across our dynamic industry and global operating environment, one thing remains constant at Dana — our commitment to integrity and ethical business practices. We have earned our customers' trust by delivering outstanding service and an unwavering commitment to ethics in all that we do, person to person.

For more than 115 years, we have been working together to build solutions that support vehicle and engine manufacturers around the world.

As we conduct business in more than 140 countries, each employee is obligated to act with the highest degree of integrity and in full compliance with the law. Continuing to drive our business in an ethical manner will help to ensure the long-term success for our people, our customers, our communities, and our shareholders.

*"WE HAVE A SHARED COMMITMENT TO PROTECT OUR REPUTATION FOR NOT ONLY DELIVERING HIGH-TECH, HIGH-QUALITY PRODUCTS, BUT ALSO CONDUCTING BUSINESS HONESTLY AND WITH INTEGRITY."*



## Bryan Kelm

**Senior Director**  
Internal Audit



"Corporate governance is all about building an environment of trust, transparency, and accountability. It's a mindset of seeing problems as treasures. It's doing business with honesty and respect for others."

"I take great pride in my role, shaping a robust culture where people conduct business legally and ethically while never compromising on values. This mindset comes from the tone at the top and cascades through the organization. As we work to ensure financial stability and business integrity, supporting stronger growth and more inclusive societies, these are standards that we live by every day."

## TRAINING AND EDUCATION

We believe that an effective corporate governance culture starts with the tone at the top, reinforcing the message that Dana conducts business in a legal, ethical, and responsible manner with a respect for human rights.

At Dana, business conduct and ethics are addressed through various programs to maintain a culture where each of us feels comfortable asking questions, speaking up, and working toward solutions. These processes include reporting, investigation and remediation, certification and audit, and continuous training and education.

Upon joining Dana, salaried employees undertake a series of mandatory new hire business conduct modules that include promoting honesty, integrity, mutual respect, and compliance with all of our policies.

We believe in ongoing training and education to ensure that employees take an active role to understand the policies affecting their job and well-being applicable at their location. In 2020, these additional mandatory trainings for all employees addressed appropriate workplace behavior and the responsible use of social media.

Ethics and compliance are also regularly integrated into other training initiatives. This includes Dana's "Leadership Foundations" program in which the next generation of Dana leadership and leaders new to Dana engage in thought-provoking exercises on topics critical to leading with integrity.



### Laurie Ryan

**Senior Business Analyst**  
IT Compliance

"I've championed compliance at Dana in one form or another for more than 25 years. My career started in the Audit department where I got a real sense of the company, analyzing processes and reporting on compliance. It's been quite an evolution since then in the I.T. world."



"Much of my day is spent working to ensure that Dana's I.T. environment is secure and we're aligned with regulatory and contractual requirements. Here, our motto 'People Finding A Better Way' really does mean something. Doing amazing things to keep Dana protected and promote the business. Being inclusive. Trying to innovate. Bringing the best out of everyone."

# Standards of Business Conduct

*Our Standards of Business Conduct set forth the behavioral expectations we have of our people as we conduct our operations around the world.*

It covers a range of subjects including respect in the workplace, environmental protection, health and safety, use of corporate assets, conflicts of interest, and protection of confidential information among many other topics.

The Standards apply to all employees of Dana. We also expect that anyone acting on our behalf — including contractors, consultants, and other third parties — will observe the same high standards of business conduct and fulfill their contractual obligations.

*"RESPECT FOR BASIC HUMAN RIGHTS AND DIGNITY RUNS THROUGH EVERY ASPECT OF DANA'S BUSINESS. IT IS A PART OF WHO WE ARE AND HOW WE CONDUCT OURSELVES."*

Dana employees have a responsibility to:

- **Conduct business legally and ethically.** To know and comply with our Standards of Business Conduct, as well as the laws, regulations, and policies that apply to their location and role at Dana.
- **Ask for guidance.** To reach out any time they are unsure of the proper course of action. This includes supervisors or heads of department, the Dana Law Department, Human Resources, or the Internal Audit Department.
- **Share concerns if misconduct is suspected.** To realize that doing nothing or looking the other way is never acceptable and can have serious consequences for them and our company.
- **Never compromise.** To always conduct business the right way — and with the right values — consistent with our Standards.

## Luciane Esteves

**Regional Legal Counsel**  
South America and Mexico



“Over my 23 years at Dana, one thing really stands out. There’s an impressive commitment to finding a better way without ever forgetting our ethical and moral values. I am so proud to be part of a Dana team that always reinforces a no-compromise approach when it comes to conducting business with integrity and honesty.”

“This backbone gives strength to our purpose across the board — regardless of geography, position, title, or tenure. This comes across in Dana’s Standards of Business Conduct, a roadmap for our company’s relationships and decisions. It also looks at the impact that our business has on the planet as well as our responsibility to protect and preserve our resources.”

## REFRESHED STANDARDS OF BUSINESS CONDUCT

In 2020, we refreshed the Standards of Business Conduct, moving to an interactive format with user-friendly navigation capabilities.

We wanted to create something capable of delivering an engaging experience whether viewed on a PC, tablet, or smartphone.

Enhanced graphics and use of images give the document a more modern look and feel, underpinning our goal to continue communicating clearly and consistently and reinforcing Dana's no-compromise approach when it comes to conducting business with integrity and honesty.

As before, the refreshed Standards promote best-in-class corporate governance across a range of topics.

- Acknowledging the impact that our business can have on our world and recognizing our responsibility to protect it and preserve our resources.
- Appreciating that we have a duty to safeguard those who use or are affected by our products and to preserve our reputation for quality.
- Ensuring that a deep held respect for basic human rights and dignity runs through every aspect of Dana's business.
- Directing our employees that their day-to-day activities are to be conducted with honesty, integrity, and respect for others.
- Driving a mindset of being active members of the communities where we live and work which means understanding our responsibility to help them be the best they can be, making positive lasting change.

Link: [Standards of Business Conduct](#)

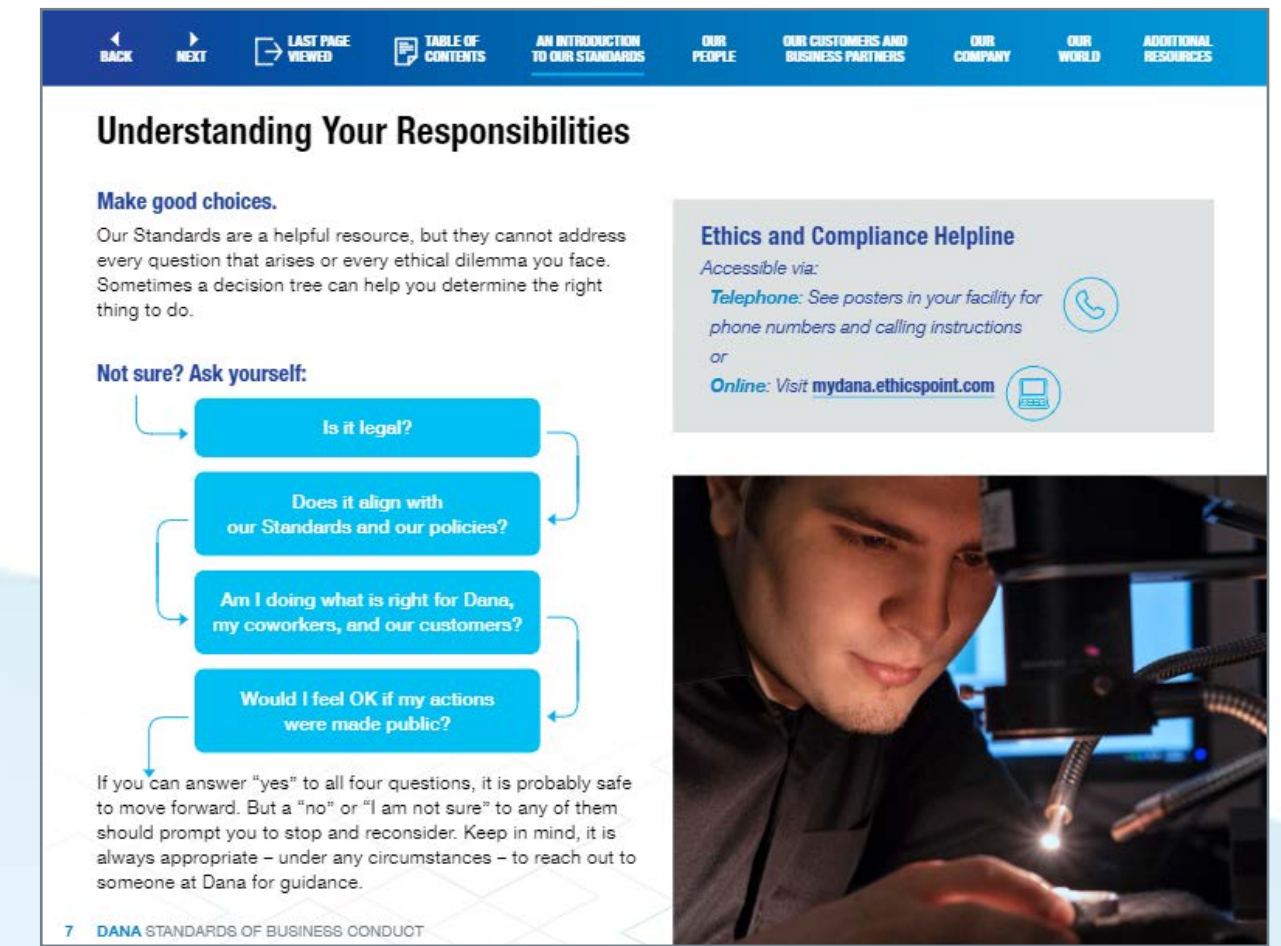
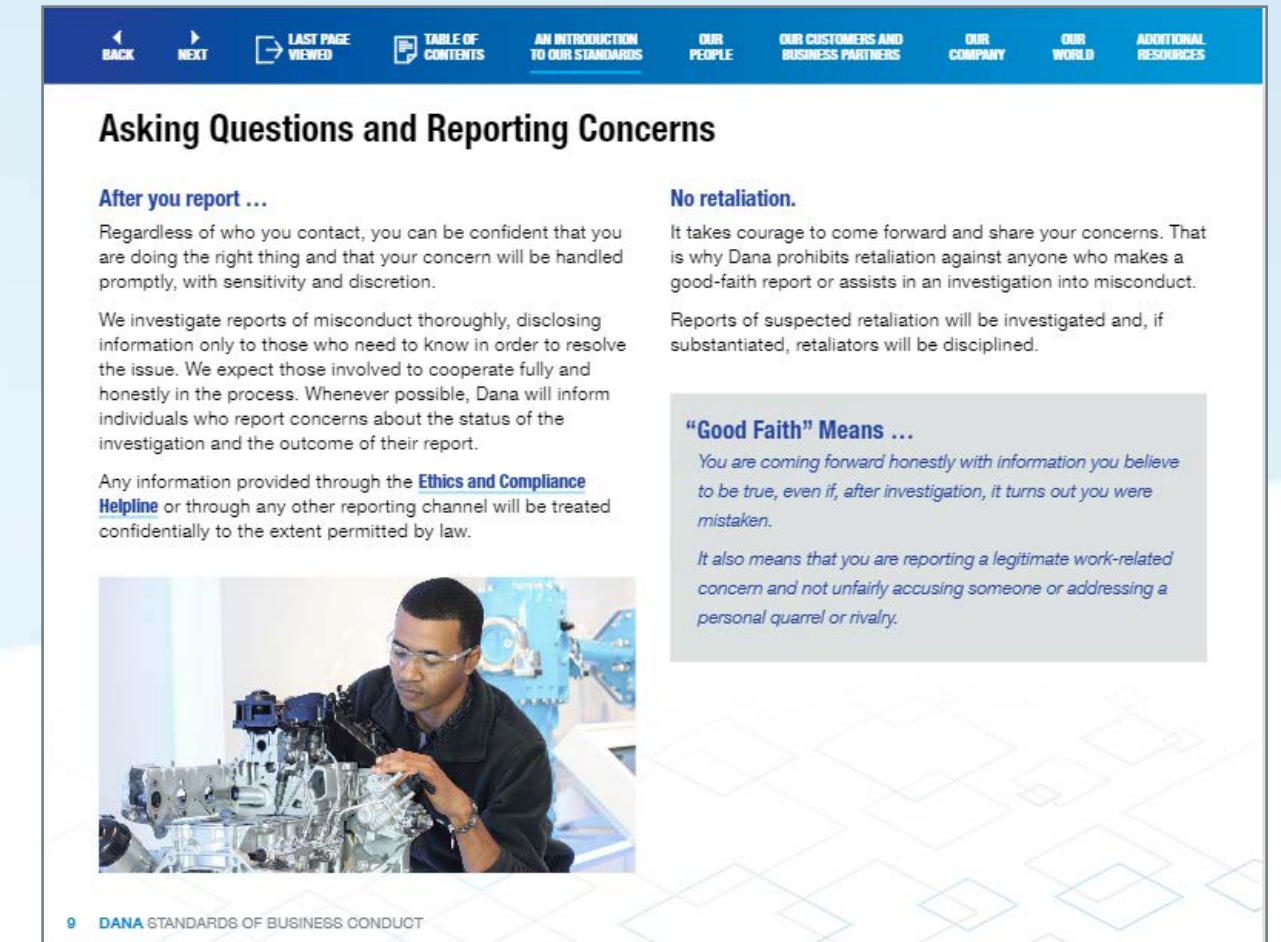
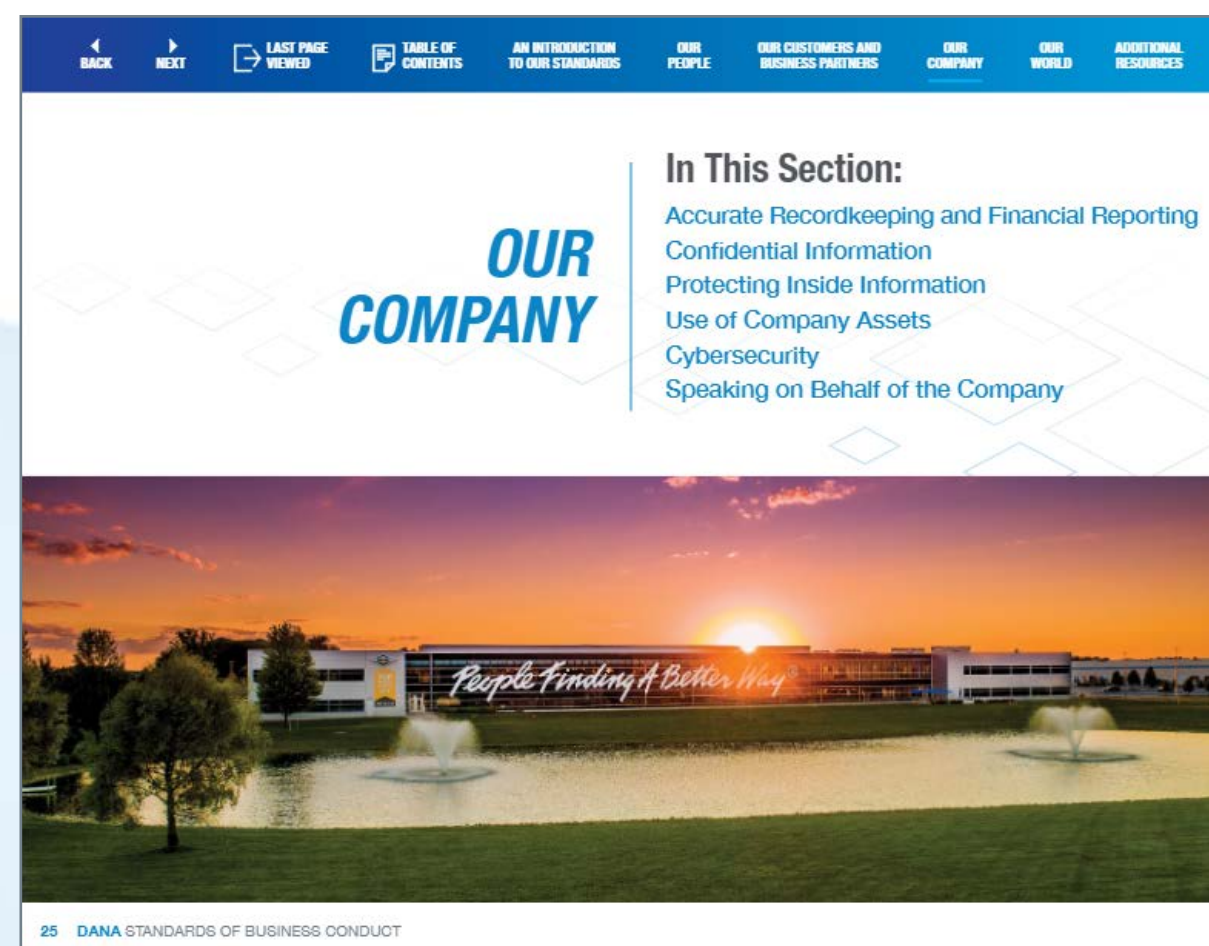

# Stakeholders

All internal and external stakeholders benefit from Dana's robust ethics and compliance programs.

Dana's Standards of Business Conduct are the cornerstone of its business conduct, ethics, and compliance programs. The Standards provide guidance to Dana people with regard to specific legal and business conduct risk areas and consequences of failure to satisfy our expectations.

Dana also maintains other core corporate, operational, and functional policies that govern the conduct of all employees. The on-boarding process for new hires involves a written acknowledgment of the receipt of the Standards of Business Conduct and other policies.

In addition, all salaried employees are expected to complete an annual questionnaire designed to identify any business conduct concerns.

Dana has a specific policy for handling internal investigations of possible business conduct and ethics violations and other matters involving fraud, theft, ethics, or financial reporting concerns. This policy establishes an affirmative obligation for employees to report ethics and business conduct matters that come to their attention. It also identifies the process for handling investigations, oversight, reporting, and related issues. Dana maintains a global Ethics and Compliance Helpline. The

Helpline is a communication tool available in multiple languages (available by both telephone and e-mail) that Dana people may use to anonymously raise concerns related to any alleged ethics or business conduct matters outside of their normal reporting channels. In 2020, Dana's Ethics and Compliance system logged 22 cases alleging discrimination or harassment, of which 17 were found to be unsubstantiated after investigation. Of the remaining cases, Dana's response was based on the facts involved in the particular matter and included coaching, other formal discipline or termination of the involved employee.

Dana's policy expectations are reinforced through systemic training and education programs. All salaried employees are expected to complete a core curriculum of ethics and compliance training programs upon joining the company, along with additional programs that are assigned each year.

Special preventative training programs covering particular risk topics are presented to target audiences on an on-going basis. Senior Dana leaders participate in a video program called "Ethics Matters," in which they address topical subjects related to ethics and compliance in a practical manner.

Ethics and compliance are regularly integrated into other training programs such as, for example, Dana's "Leadership Foundations" program, which include thought-provoking discussions and exercises on topics critical to leadership.

## Lisa Long

**Layout Technician**  
Metrology

"Everything that enters our Paris, Tennessee, facility — cam covers, gaskets, power steering, engine oil coolers — goes through our metrology lab. Here, we use computers to verify that parts meet specific specifications. Of course, there's a strong focus on quality and satisfying customer requirements. Equally, there's an established culture around being open about things, finding solutions, not hiding or passing off problems."

"For me this is central to the Dana way. It's about doing it right with a team of people who are there for each other. Who can smile even when the going gets tough and the pressure's on. They really are like a second family to me — both inside and outside of work."



## ROBUST CYBERSECURITY

*Our global cybersecurity teams protect the data and integrity of computing devices belonging to or connecting to Dana's network — ensuring that the reputational, operational, legal, and compliance implications of cybersecurity risks are addressed.*

In 2020, the U.S. Federal Bureau of Investigation reported a 300% increase in fraud schemes related to the pandemic, which created new challenges for businesses as they accelerated their digital transformation and adapted to an operating model in which working from home became the new normal.

Throughout the pandemic, our proactive focus on next-generation endpoint protection and vulnerability management has been our biggest strength from a cybersecurity perspective. In early 2020, we securely established and stabilized a remote-work environment to accommodate a 30-fold increase in the number of daily remote users. If people needed to get to a Dana application, we ensured that the correct authentication protocols were in place.

This encompassed moving 15,000 employees to Microsoft Teams and registering thousands of Dana colleagues and external partners for multi-factor authentication to boost additional security across our applications.

Dana's Information Security Policy aligns to ISO 27001 and follows the National Institute of Standards and Technology (NIST) framework controls. Dana conducts self-assessments each year and third party audits against the NIST framework.

Training and development will continue to play an important role in protecting systems from cyberattacks. As such, Dana employees undertake mandatory annual cybersecurity training to educate them on dangerous threats so that they can learn to recognize and report real attacks — in addition to supplemental training programs available each year.

Four key tenets underpin Dana's robust cyber security strategy as it engages across the entire company to protect our people and increasingly digitized business operations.



## POLICIES

### CONFLICT MINERALS

As a company with sales and manufacturing operations throughout the world, Dana supports the sourcing of minerals responsibly, as set out in the Standards of Business Conduct.

We support ending any violence and human rights violations in the mining of certain minerals from a location described as the “Conflict Region” (the Democratic Republic of the Congo (“DRC”) and neighboring countries). We support these requirements to further the humanitarian goal of ending violent conflict in the DRC and in surrounding countries, which has been partially financed by the exploitation and trade of conflict minerals.

We are committed to:

- Supporting the aims and objectives of U.S. legislation regarding the supply of conflict minerals;
- Not procuring specified metals that originate from facilities in the “Conflict Region” that are not certified as “conflict-free”; and
- Ensuring compliance with these requirements, and we require our suppliers to undertake reasonable due diligence within their supply chains to assure that specified metals are being sourced only from:
  - Mines and smelters outside the “Conflict Region,” or
  - Mines and smelters which have been certified by an independent third party as “conflict-free” if sourced within the “Conflict Region.”

In the event that we would ever discover that the use of minerals produced in facilities that are considered to be “non- conflict-free,” in any of the material, parts, or components that we procure, we would take appropriate prompt actions to transition to a product that would be “conflict-free.”

### HUMAN RIGHTS

Respect for basic human rights and dignity is a fundamental part of Dana’s culture. It is a part of who we are and how we conduct business. We are committed to following the laws that ensure fairness and dignity in employment and prohibit abusive employment practices. Dana’s Standards of Business Conduct state, “Each Dana person is obligated to conduct Dana’s business in a legal, ethical, and responsible manner with a respect for human rights.”

In addition, Dana’s policy on human rights and sustainability & social responsibility set forth Dana’s commitment to respect people, respect communities, respect the environment, and to respect laws, ethics, and fairness. Dana also maintains policies and procedures that prohibit and guard against human trafficking and utilization of conflict minerals.

### Haiying Li

**Head of Purchasing**  
China

“My work supporting Dana’s purchasing activities includes production material and non-production material for our Electrification, Off-Highway, Power Technology, Light Vehicle, and Commercial Vehicle businesses.”



“As we develop long-term relationships of trust with Dana suppliers, we always take the bigger picture into account. Naturally, quality and cost are important drivers. But we also factor in suppliers’ track records on sustainability, human rights, and diversity. At the end of the day, we all share this planet. We have a shared responsibility to build a better world and brighter future for the next generation.”



## HUMAN TRAFFICKING

Dana is committed to carrying out business responsibly, sustainably, and ethically. This includes ensuring that modern slavery and human trafficking are not taking place in any part of our business or supply chain. Our commitments include:

- Actions to combat modern slavery and human trafficking,
- Doing business in an ethical manner and with respect for our people and the communities in which they live, and
- Respect for human rights issues, including combatting any abuses of them, whether through human trafficking, modern slavery, child labor or otherwise.

## LABOR

Dana has long been committed to the principles of freedom of association for its employees and maintaining an open and productive relationship with unions who represent our employees in the various countries where we conduct business. This respect for the rights of our employees also extends to a recognition of the employee's right to communicate their views on wages, hours, and working conditions. Further, in the U.S. and Canada, we have maintained a neutrality agreement with our major unions for many years regarding efforts to organize plant locations.

## CORPORATE POLICIES

- [Anti-Corruption](#)
- [Antitrust and Competition Law](#)
- [Conflicts of Interest](#)
- [Environmental](#)
- [Gifts and Entertainment](#)
- [Health and Safety](#)
- [Human Rights and Sustainability & Social Responsibility](#)
- [Internal Investigations of Business Conduct, Ethics and Legal Compliance Concerns](#)
- [Political Contributions](#)

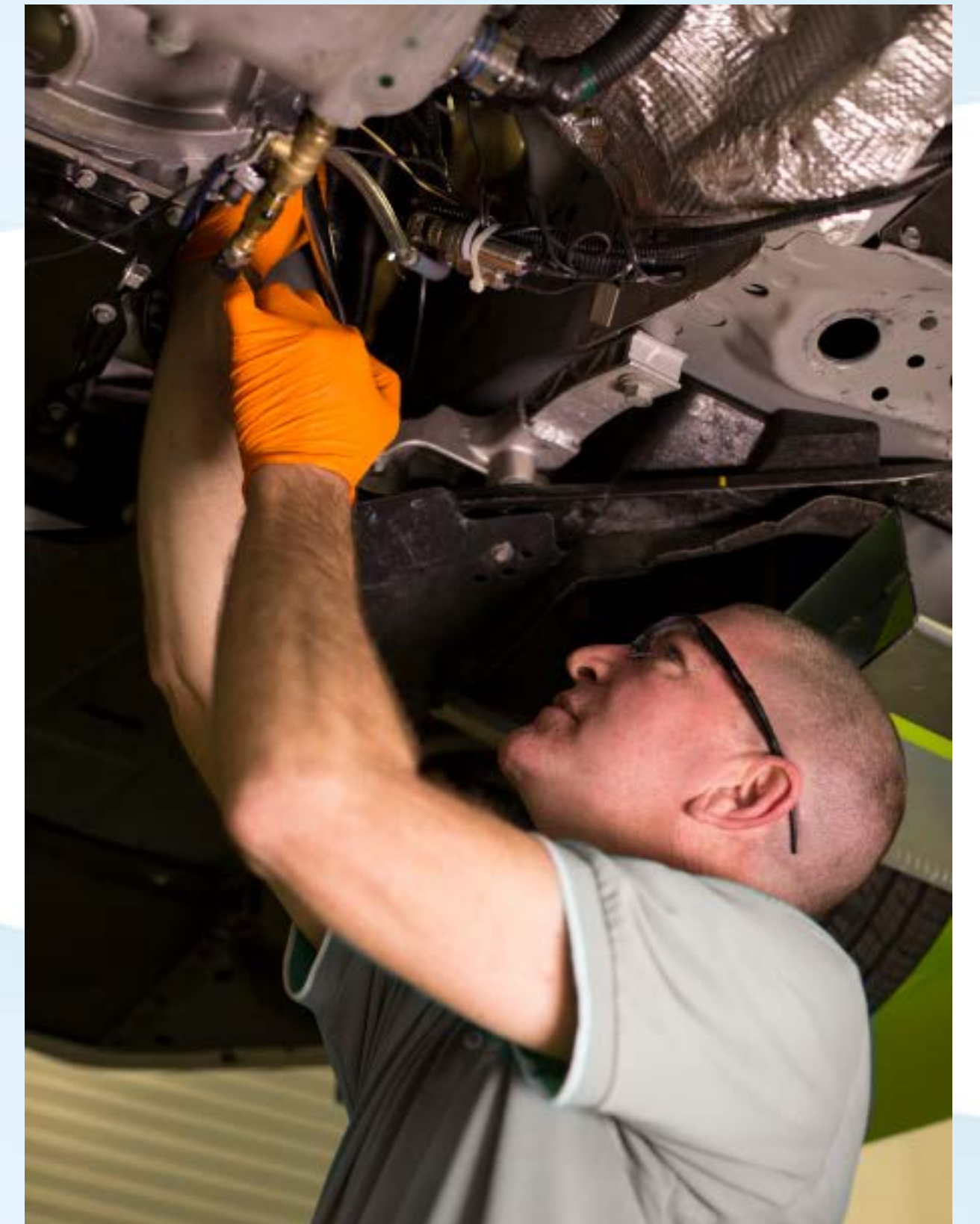



# Dana Leadership

## BOARD OF DIRECTORS

### Rachel A. Gonzalez <sup>1,3</sup>

Executive Vice President, General Counsel, and Secretary of Starbucks Corporation

**Director since 2017**

### James K. Kamsickas

Chairman and Chief Executive Officer of Dana Incorporated

**Director since 2015**

### Virginia A. Kamsky <sup>2,3\*</sup>

Chairman and Chief Executive Officer of Kamsky Associates, Inc.

**Director since 2011**

### Bridget E. Karlin <sup>3,4</sup>

Global Chief Technology Officer and Vice President of IBM Global Technology Services

**Director since 2020**

### Raymond E. Mabus, Jr. <sup>2,4</sup>

Founding Principal and Chief Executive Officer of The Mabus Group

**Director since 2017**

### Michael J. Mack <sup>1,2</sup>

Retired Group President of John Deere Financial Services, Global Human Resources, and Public Affairs at Deere & Co.

**Director since 2018**

### R. Bruce McDonald <sup>1,2\*</sup>

Retired Chairman and Chief Executive Officer of Adient plc

**Director since 2014**

### Diarmuid B. O'Connell <sup>1,4\*</sup>

Former Vice President of Tesla, Inc.

**Director since 2018**

### Keith E. Wandell <sup>3,†</sup>

Retired President, Chief Executive Officer, and Chairman of Harley-Davidson, Inc.

**Director since 2008**

<sup>1</sup> Member, Compensation Committee

<sup>2</sup> Member, Audit Committee

<sup>3</sup> Member, Nominating and Corporate Governance Committee

<sup>4</sup> Member, Technology and Sustainability Committee

\* Committee Chair

† Lead Independent Director

For full biographies, please refer to [Dana.com/investors](http://Dana.com/investors)

## CORPORATE OFFICERS

**James K. Kamsickas**

Chairman and  
Chief Executive Officer

**Aziz S. Aghili**

Executive Vice President and  
President, Heavy Vehicle

**Shelley R. K. Bridarolli**

Senior Vice President,  
Human Resources

**Chris J. Clark**

Senior Vice President,  
Global Operations

**Jonathan M. Collins**

Executive Vice President and  
Chief Financial Officer

**Christophe J. Dominiak**

Senior Vice President and  
Chief Technology Officer

**Matthew H. Fahnestock**

Senior Vice President and  
Chief Information Officer

**Byron S. Foster**

Senior Vice President and Chief Commercial,  
Marketing, and Communications Officer

**James D. Kellett**

Vice President and  
Chief Accounting Officer

**Timothy R. Kraus**

Senior Vice President,  
Tax and Treasury

**Douglas H. Liedberg**

Senior Vice President, General Counsel,  
Secretary, and Chief Compliance and  
Sustainability Officer

**M. Craig Price**

Senior Vice President,  
Purchasing and Supplier Development

**Robert D. Pyle**

Executive Vice President and  
President, Light Vehicle Drive Systems

**Antonio Valencia**

President, Power Technologies and  
Global Electrification

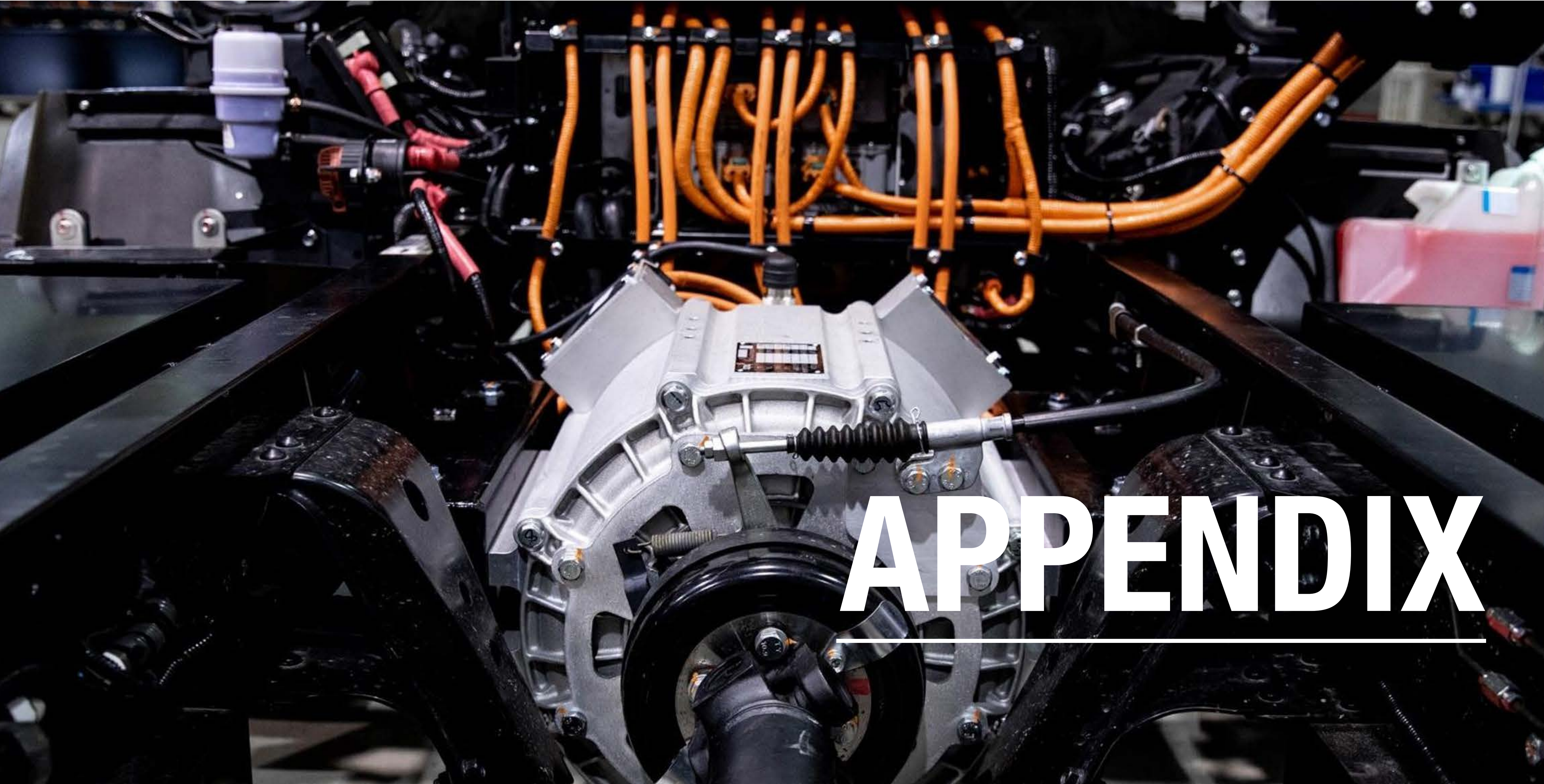

# APPENDIX

---

# Methodology

*Using the Global Reporting Initiative (GRI) guidance, we identified possible topics, prioritized the topics, validated the results, and adopted the list of material topics for our Sustainability and Social Responsibility reporting strategy.*

## Step 1: Identification

- Identified internal and external sources of information to score for prioritization.
- Benchmarked our competitors/peers on sustainability and social responsibility practices.
- Created a high-level value chain map to identify sustainability and social responsibility impacts, risks, opportunities, and boundaries.

## Step 2: Prioritization

- Gathered perceptions of stakeholder priorities based on associated facts and evidence, including 18 internal stakeholder interviews, 21 external stakeholder interviews, and internal/external score sourcing.
- Scored and synthesized feedback to present final materiality results reflecting feedback from stakeholders, peer benchmarking, and relevant industry standards and studies.

## Step 3: Validation

- Validated the materiality matrix through discussion with key leaders about prioritized material topics, associated boundaries, and opportunities.

## Step 4: Adoption

- Determined and/or refined the management approach regarding the most significant topics.
- Set or refined goals, performance indicators, strategies, partnerships, and internal controls.
- Established the materiality assessment as the basis for ongoing ESG strategy, goal setting, and reporting.

## MATERIAL TOPICS

Issues
1. Innovation and Product Lifecycle
2. Talent Management
3. Occupational Health, Safety and Wellness
4. Ethical Business Practices
5. Diversity and Equal Opportunity
6. Business Continuity / Risk Mitigation / Supply Chain
7. Product Quality and Safety
8. Energy Consumption and Emissions
9. Solid Waste
10. Water and Effluents

## STAKEHOLDER ENGAGEMENT

Continuous engagement and regular dialogue with our seven defined stakeholder groups, through formal and informal processes, provides us the opportunity to innovate and proactively manage the emerging environmental, social, and governance (ESG) needs and risks.

In addition to ongoing internal stakeholder engagement, we regularly engage with our external stakeholders on trending and emerging issues that matter to them through inquiries and requests for information related to our ESG practices as well as through periodic surveys answered at the request of various customers and investors.

In addition to engaging with internal and external stakeholders to evolve our ESG execution, we understand that increased transparency helps us effectively improve our business over the long term.

A list of external charters and associations Dana is actively engaged with include:

- American Bar Association Diversity & Inclusion Initiative
- American Society of Safety Professionals (ASSP)
- Association of Equipment Manufacturers (AEM)
- Automotive Industry Action Group (AIAG)
- Board of Certified Safety Professionals (CSP)
- CEO Action for Diversity & Inclusion
- CDP (fka Carbon Disclosure Project)
- Global Reporting Initiative (GRI)
- Human Rights Campaign Corporate Equality Index
- Institute of Hazardous Materials Management (IHMM)
- Institutional Shareholder Services (ISS)
- Manufacturers Alliance for Productivity and Innovation (MAPI)
- Sustainable Accounting Standards Board (SASB)
- United Nations Sustainable Development Goals (SDGs)
- Task Force on Climate-related Financial Disclosures (TCFD)

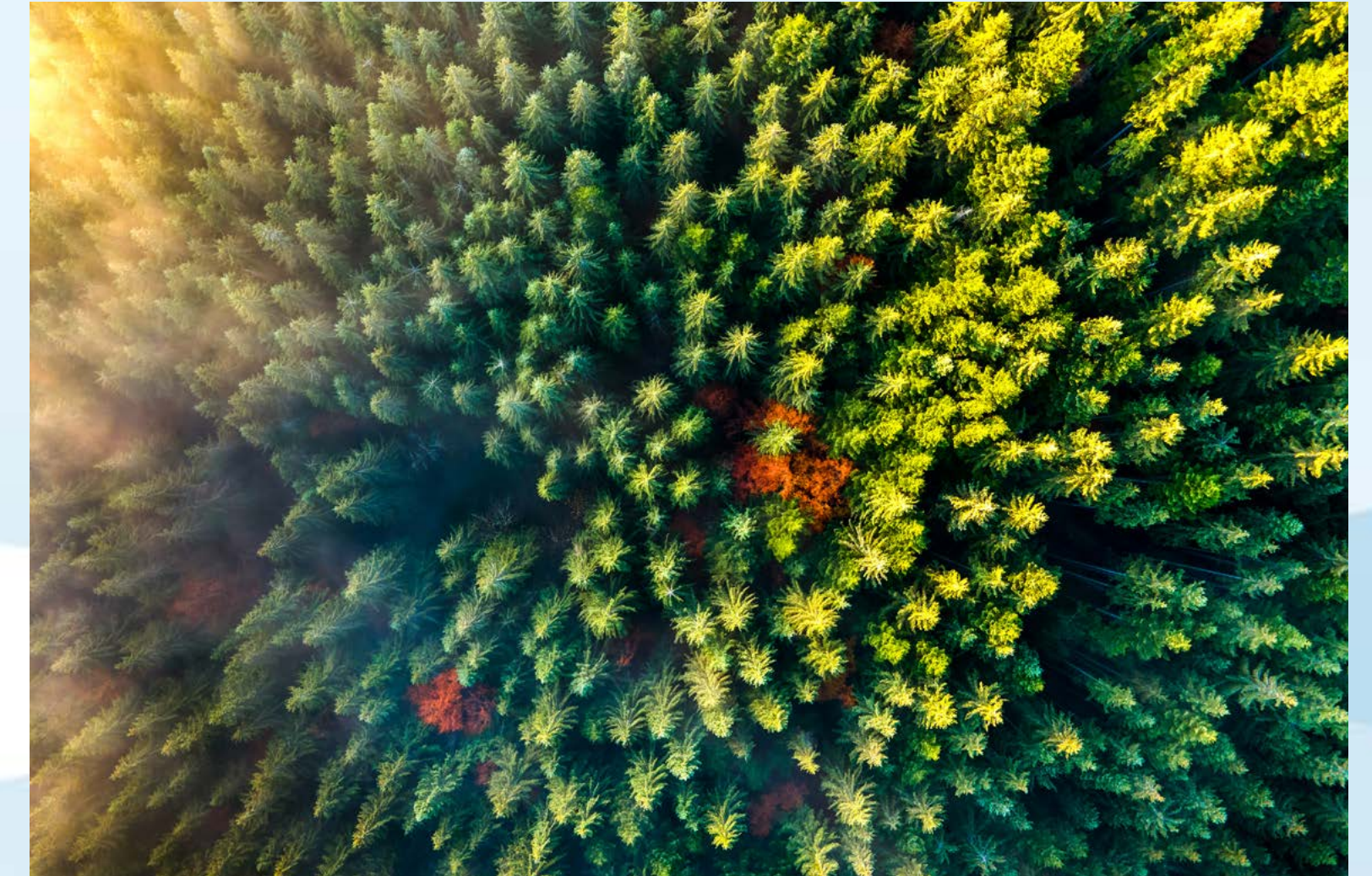

# Global Reporting Initiative and United Nations Sustainable Development Goals Index

The Global Reporting Initiative (GRI) is the independent international organization that helps businesses and other organizations take responsibility for their impacts, by providing global common language to communicate those impacts. They provide the world's most widely used standards for sustainability reporting — the GRI Standards.

The 2030 Agenda for Sustainable Development, adopted by all United Nations Member States in 2015, provides a shared blueprint for peace and prosperity for people and the planet, now and into the future. At its heart are the 17 Sustainable Development Goals (SDGs), which are an urgent call for action by all countries — developed and developing — in a global partnership. They recognize that ending poverty and other deprivations must go hand-in-hand with strategies that improve health and education, reduce inequality, and spur economic growth — all while tackling climate change and working to preserve our oceans and forests.

Within the report index, Dana is providing the linkages between the reporting framework content — Global Reporting Initiative (GRI), Sustainable Accounting Standards Board (SASB), and Task Force on Climate-related Financial Disclosures (TCFD) — and their relationship with the 17 United Nations SDGs listed to the right.



Disclosure Number	Disclosure Title	2020 Response	SDGs
<b>GRI 102: General Disclosures</b>			
<b>Organizational Profile</b>			
102-1	Name of the organization	Dana Incorporated	NA
102-2	Activities, brands, products, and services	Dana 2020 Sustainability & Social Responsibility Report: Dana: Products <a href="#">Dana 2020 Annual Report</a> pages 1 - 23	NA
102-3	Location and headquarters	Dana's corporate offices are located at: Dana Incorporated 3939 Technology Drive Maumee, OH 43537, USA	NA
102-4	Location of operations	<a href="#">Locations</a>	NA
102-5	Ownership and legal form	Dana Incorporated (NYSE: DAN) is a publicly held corporation incorporated in the state of Delaware. Our shares trade on the New York Stock Exchange.	NA
102-6	Markets served	Dana 2020 Sustainability & Social Responsibility Report: Dana: Business Units <a href="#">Dana 2020 10-K</a> pages 1 & 2	NA
102-7	Scale of the organization	Dana 2020 Sustainability & Social Responsibility Report: Sales Snapshot <a href="#">Dana 2020 10-K</a> page 3 & 4	NA
102-8	Information on employees and other workers	Dana 2020 Sustainability & Social Responsibility Report: Employment Data <a href="#">Dana 2020 10-K</a> pages 5 & 6	NA
102-9	Supply chain	Dana 2020 Sustainability & Social Responsibility Report: Products / Driving a Sustainable Supply Chain <a href="#">Dana 2020 10-K</a> page 3	NA
102-10	Significant changes to the organization and its supply chain	Dana 2020 Sustainability & Social Responsibility Report: Products / Electrification Delivered <a href="#">Dana 2020 10-K</a> pages 16 - 20	NA
102-11	Precautionary principle or approach	Dana has applied the precautionary principle in its approach to managing greenhouse gas emissions and their effect on global climate change.	NA
102-12	External initiatives	Dana 2020 Sustainability & Social Responsibility Report: Appendix - Stakeholder Engagement	SDG 17
102-13	Membership of associations	Dana 2020 Sustainability & Social Responsibility Report: Appendix - Stakeholder Engagement	SDG 17



<b>Strategy</b>			
102-14	Statement from senior decision-maker	Dana 2020 Sustainability & Social Responsibility Report: A Message from the CEO	NA
102-15	Key impacts, risks, and opportunities	<a href="#">Dana 2020 10-K</a> pages 7 - 12	NA
<b>Ethics and Integrity</b>			
102-16	Values, principles, standards, and norms of behavior	Dana 2020 Sustainability & Social Responsibility Report: Governance <a href="#">Standards of Business Conduct</a>	SDG 3
102-17	Mechanisms for advice and concerns about ethics	Dana 2020 Sustainability & Social Responsibility Report: Governance <a href="#">Internal Investigations Policy</a>	SDG 16
<b>Governance</b>			
102-18	Governance structure	Dana 2020 Sustainability & Social Responsibility Report: Governance <a href="#">Technology &amp; Sustainability Committee</a> <a href="#">Sustainability &amp; Social Responsibility Governance</a>	SDG 16
102-19	Delegating authority	Technology & Sustainability Committee <a href="#">Sustainability &amp; Social Responsibility Governance</a>	SDG 16
102-20	Executive-level responsibility for economic, environmental, and social topics	<a href="#">Sustainability &amp; Social Responsibility Governance</a>	SDG 16
102-21	Consulting stakeholders on economic, environmental, and social topics	Dana 2020 Sustainability & Social Responsibility Report: Appendix - Methodology	SDG 16
102-22	Composition of the highest governance body and its committees	<a href="#">Board of Directors</a> <a href="#">Corporate Governance</a> <a href="#">Sustainability &amp; Social Responsibility Governance</a> <a href="#">Dana 2021 Proxy</a> , page 42	SDG 16
102-23	Chair of the highest governance body	<a href="#">Dana 2021 Proxy</a> , pages 40 & 41	SDG 16

102-24	Nominating and selecting the highest governance body	<a href="#">Corporate Governance</a> <a href="#">Dana 2021 Proxy</a> , page 43 <a href="#">Director Selection and Retention Guidelines</a>	SDG 16
102-25	Conflicts of interest	<a href="#">Standards of Business Conduct Policy for Members of the Board of Directors</a>	SDG 16
102-26	Role of highest governance body in setting purpose, values, and strategy	<a href="#">Corporate Governance Guidelines</a>	SDG 16
102-27	Collective knowledge of highest governance body	<a href="#">Dana Board of Directors</a> <a href="#">Dana 2021 Proxy</a> , pages 37 - 39	SDG 16
102-28	Evaluating the highest governance body's performance	<a href="#">Corporate Governance Guidelines</a> , page 6 <a href="#">Dana 2021 Proxy</a> , page 40	SDG 16
102-29	Identifying and managing economic, environmental, and social impacts	<a href="#">Technology &amp; Sustainability Committee Charter</a> , page 1, items 5 - 7 <a href="#">Sustainability &amp; Social Responsibility Governance</a>	SDG 16
102-30	Effectiveness of risk management processes	<a href="#">Dana 2020 10-K</a> pages 7 - 12 <a href="#">Dana 2021 Proxy</a> , page 41	SDG 16
102-31	Review of economic, environmental, and social topics	<a href="#">Sustainability &amp; Social Responsibility Governance</a> <a href="#">Dana 2021 Proxy</a> , page 43	SDG 16
102-32	Highest governance body's role in sustainability reporting	<a href="#">Technology &amp; Sustainability Committee Charter</a> <a href="#">Sustainability &amp; Social Responsibility Governance</a>	SDG 16

102-33	Communicating critical concerns	<p>Go to <a href="http://www.dana.com/investors">www.dana.com/investors</a> to find the latest investor relations information about Dana, including stock quotes, news releases, and financial data.</p> <p>Requests for information may be directed to:</p> <p>Investor Relations Dana Incorporated P.O. Box 1000 Maumee, OH 43537-7000, USA</p> <p>E-mail: <a href="mailto:InvestorRelations@dana.com">InvestorRelations@dana.com</a> Dana's Investor Line: 800-537-8823</p> <p>Through this 24-hour phone service, a caller may leave his or her name with a message, and the call will be returned by a Dana representative.</p>	SDG 16
102-34	Nature and total number of critical concerns	This information is considered confidential.	SDG 16
102-35	Remuneration policies	<a href="#">Dana 2021 Proxy</a> , pages 20 - 22	SDG 16
102-36	Process for determining remuneration	<a href="#">Dana 2021 Proxy</a> , pages 9 - 20	SDG 16
102-37	Stakeholders' involvement in remuneration	<a href="#">Dana 2021 Proxy</a> , page 49	SDG 16
102-38	Annual total compensation ratio	<a href="#">Dana 2021 Proxy</a> , page 35	SDG 16
102-39	Percentage increase in annual total compensation ratio	<a href="#">Dana 2021 Proxy</a> , page 35	SDG 16

<b>Stakeholder Engagement</b>			
102-40	List of stakeholder groups	Dana 2020 Sustainability & Social Responsibility Report: Appendix - Methodology	NA
102-41	Collective bargaining agreements	In 2020, 44% of all employees were covered by a collective bargaining agreement.	NA
102-42	Identifying and selecting stakeholders	Dana 2020 Sustainability & Social Responsibility Report: Appendix - Methodology	NA
102-43	Approach to stakeholder engagement	Dana 2020 Sustainability & Social Responsibility Report: Appendix - Methodology	NA
102-44	Key topics and concerns raised	Dana 2020 Sustainability & Social Responsibility Report, Appendix - Methodology	NA
<b>Reporting Practices</b>			
102-45	Entities included in the consolidated financial statements	<a href="#">Dana 2020 10-K</a> , page 13	NA
102-46	Defining report content and topic Boundaries	Dana 2020 Sustainability & Social Responsibility Report: Appendix - Methodology	NA
102-47	List of material topics	Dana 2020 Sustainability & Social Responsibility Report: Appendix - Material Topics	NA
102-48	Restatements of information	Refer to graph footnote on page 50 and 58.	NA
102-49	Changes in reporting	None	NA
102-50	Reporting period	Dana 2020 Sustainability & Social Responsibility Report: Cover Page	NA
102-51	Date of most recent report	April 2021	NA
102-52	Reporting cycle	Dana 2020 Sustainability & Social Responsibility Report: Cover Page	NA
102-53	Contact point for questions regarding the report	Please send any questions regarding the report to: <a href="mailto:sustainability@dana.com">sustainability@dana.com</a>	NA
102-54	Claims of reporting in accordance with the GRI Standards	Dana 2020 Sustainability & Social Responsibility Report: Appendix - GRI Content Index	NA
102-55	GRI content index	Dana 2020 Sustainability & Social Responsibility Report: Appendix - GRI Content Index	NA
102-56	External assurance	The Dana 2020 Sustainability & Social Responsibility Report has not been externally reviewed and verified as of the release date.	SDG 16

<b>Topic-Specific Standards</b>			
<b>GRI 204: Procurement Practices</b>			
103-1	Explanation of the material topic and its boundary	Dana 2020 Sustainability & Social Responsibility Report: Appendix / Methodology	NA
103-2	The management approach and its components	Dana 2020 Sustainability & Social Responsibility Report: Products / Sustainable Supply Chain	SDG 12
103-3	Evaluation of the management approach	Dana 2020 Sustainability & Social Responsibility Report: Products / Sustainable Supply Chain	SDG 12
204-1	Proportion of spending on local suppliers	Dana works with thousands of suppliers around the world, including many suppliers located near our customers' operations.	SDG 12
<b>GRI 205: Anti-Corruption</b>			
103-1	Explanation of the material topic and its boundary	Dana 2020 Sustainability & Social Responsibility Report: Appendix / Methodology	NA
103-2	The management approach and its components	Dana 2020 Sustainability & Social Responsibility Report: Governance	SDG 16
103-3	Evaluation of the management approach	Dana 2020 Sustainability & Social Responsibility Report: Governance	SDG 16
205-1	Operations assessed for risks related to corruption	Dana has a robust internal audit program including audit procedures specifically focused on business conduct.	SDG 16
205-2	Communication and training about anti-corruption policies and procedures	Dana 2020 Sustainability & Social Responsibility Report: Governance	SDG 16
205-3	Confirmed incidents of corruption and actions taken	This information is considered confidential.	SDG 16

<b>GRI 206: Anti-Competitive Behavior</b>			
103-1	Explanation of the material topic and its boundary	Dana 2020 Sustainability & Social Responsibility Report: Appendix / Methodology	NA
103-2	The management approach and its components	Dana 2020 Sustainability & Social Responsibility Report: Governance	SDG 16
103-3	Evaluation of the management approach	Dana 2020 Sustainability & Social Responsibility Report: Governance	SDG 16
206-1	Legal actions for anti-competitive behavior, anti-trust, and monopoly practices	Dana's public filings would identify any significant pending proceedings.	SDG 16
<b>GRI 302: Energy</b>			
103-1	Explanation of the material topic and its boundary	Dana 2020 Sustainability & Social Responsibility Report: Appendix / Methodology	NA
103-2	The management approach and its components	Dana 2020 Sustainability & Social Responsibility Report: Planet / Tackling Climate Change	SDG 12, 13
103-3	Evaluation of the management approach	Dana 2020 Sustainability & Social Responsibility Report: Planet / Tackling Climate Change	SDG 12, 13
302-1	Energy consumption within the organization	99.6% electricity purchased from traditional energy providers Dana 2020 Sustainability & Social Responsibility Report: Planet / Tackling Climate Change and the graph detailing Total Energy Consumption (MWh)	SDG 7, 12, 13
302-2	Energy consumption outside of the organization	Scope 3 emissions for 2020 will be included in the 2021 CDP submission	SDG 7, 12, 13
302-3	Energy intensity	Dana 2020 Sustainability & Social Responsibility Report: Planet / Tackling Climate Change and graphs detailing Normalized GHG Emissions (kg CO <sup>2</sup> -e per hour worked) and Normalized GHG Emissions (kg CO <sup>2</sup> -e per mil \$ sales)	SDG 7, 12, 13
302-4	Reduction of energy consumption	Dana 2020 Sustainability & Social Responsibility Report: Planet / Tackling Climate Change and the graph detailing Total Energy Consumption (MWh)	SDG 7, 12, 13
302-5	Reduction in energy requirements of products and services	Dana 2020 Sustainability & Social Responsibility Report: Products / Electrification Delivered	SDG 9, 13

<b>GRI 303: Water &amp; Effluents</b>			
103-1	Explanation of the material topic and its boundary	Dana 2020 Sustainability & Social Responsibility Report: Appendix / Methodology	NA
103-2	The management approach and its components	Dana 2020 Sustainability & Social Responsibility Report: Planet / The Importance of Conserving Water	SDG 12, 14
103-3	Evaluation of the management approach	Dana 2020 Sustainability & Social Responsibility Report: Planet / The Importance of Conserving Water	SDG 12, 14
303-1	Interactions with water as a shared resource	Water interactions for 2020 will be included in the 2021 CDP submission	SDG 12, 14
303-2	Management of water discharge-related impacts	Water discharge for 2020 will be included in the 2021 CDP submission	SDG 12, 14
303-3	Water withdrawal	Dana 2020 Sustainability & Social Responsibility Report: Planet / The Importance of Conserving Water and graphs detailing Total Water Consumption (m <sup>3</sup> ) and Total Normalized Water Consumption (m <sup>3</sup> per hour worked)	SDG 6, 12, 14
303-4	Water discharge	Water discharge for 2020 will be included in the 2021 CDP submission	SDG 12, 14
303-5	Water consumption	Water consumption for 2020 will be included in the 2021 CDP submission	SDG 6, 12, 14
<b>GRI 305: Emissions</b>			
103-1	Explanation of the material topic and its boundary	Dana 2020 Sustainability & Social Responsibility Report: Appendix / Methodology	NA
103-2	The management approach and its components	Dana 2020 Sustainability & Social Responsibility Report: Planet / Tackling Climate Change	SDG 7, 12, 13
103-3	Evaluation of the management approach	Dana 2020 Sustainability & Social Responsibility Report: Planet / Tackling Climate Change	SDG 7, 12, 13
305-1	Energy: Direct (Scope 1) GHG emissions	Dana 2020 Sustainability & Social Responsibility Report: Planet / Tackling Climate Change and graphs detailing 2020 GHG Emissions by Scope (kg CO <sub>2</sub> -e) and 2020 Energy Consumption by Type (MWh)	SDG 7, 12, 13
305-2	Energy: Indirect (Scope 2) GHG emissions	Dana 2020 Sustainability & Social Responsibility Report: Planet / Tackling Climate Change and graphs detailing 2020 GHG Emissions by Scope (kg CO <sub>2</sub> -e) and 2020 Energy Consumption by Type (MWh)	SDG 7, 12, 13
305-3	Energy: Other indirect (Scope 3) GHG emissions	Scope 3 emissions information for 2020 will be included in the 2021 CDP submission.	SDG 7, 12, 13



305-4	GHG emissions intensity	Dana 2020 Sustainability & Social Responsibility Report: Planet / Tackling Climate Change and graphs detailing Normalized GHG Emissions (kg CO <sup>2</sup> -e per hour worked) and Normalized GHG Emissions (kg CO <sup>2</sup> -e per mil \$ sales)	SDG 7, 12, 13
305-5	Reduction of GHG emissions	Dana 2020 Sustainability & Social Responsibility Report: Planet / Tackling Climate Change and graphs detailing Normalized GHG Emissions (kg CO <sup>2</sup> -e per hour worked), Normalized GHG Emissions (kg CO <sup>2</sup> -e per mil \$ sales), and Total Greenhouse Gas Emissions (kg CO <sub>2</sub> -e)	SDG 7, 12, 13
305-6	Emissions of ozone-depleting substances (ODS)	Ozone-depleting substance emissions for 2020 will be included in the 2021 CDP submission.	SDG 7, 12, 13
305-7	Nitrogen oxides (NO <sub>x</sub> ), sulfur oxides (SO <sub>x</sub> ), and other significant air emissions	<p>Significant emissions from combustion of fuels in 2020, include:</p> <p>Particulate Matter: 13,784 kg</p> <p>Nitrogen Oxides: 189,272 kg</p> <p>Sulfur Oxides: 5,138 kg</p> <p>Carbon Monoxide: 114,759 kg</p> <p>Volatile Organic Compounds: 15,966 kg</p> <p>Hazardous Air Pollutants: 59 kg</p> <p>Calculation Source: AP-42 Fifth Edition, Tables 3.3-1, 10/96 Update</p>	SDG 12, 13
<b>GRI 306: Effluents and Waste</b>			
103-1	Explanation of the material topic and its boundary	Dana 2020 Sustainability & Social Responsibility Report: Appendix / Methodology	NA
103-2	The management approach and its components	Dana 2020 Sustainability & Social Responsibility Report: Planet / Environmental Stewardship	SDG 12, 15
103-3	Evaluation of the management approach	Dana 2020 Sustainability & Social Responsibility Report: Planet / Environmental Stewardship	SDG 12, 15
306-1	Waste generation and significant waste-related impacts	Dana 2020 Sustainability & Social Responsibility Report: Planet / Environmental Stewardship and graphs detailing 2020 Hazardous Waste by Treatment Method (kg) and 2020 Non-Hazardous Waste by Treatment Method (kg)	SDG 12, 15
306-2	Management of significant waste-related impacts	Dana 2020 Sustainability & Social Responsibility Report: Planet / Environmental Stewardship and graphs detailing 2020 Hazardous Waste by Treatment Method (kg) and 2020 Non-Hazardous Waste by Treatment Method (kg)	SDG 12, 15



306-3	Waste generated	Dana 2020 Sustainability & Social Responsibility Report: Planet / Environmental Stewardship and graphs detailing 2020 Hazardous Waste by Treatment Method (kg) and 2020 Non-Hazardous Waste by Treatment Method (kg)	SDG 12, 15
306-4	Waste diverted from disposal	Dana 2020 Sustainability & Social Responsibility Report: Planet / Environmental Stewardship and graphs detailing 2020 Hazardous Waste by Treatment Method (kg) and 2020 Non-Hazardous Waste by Treatment Method (kg)	SDG 12, 15
306-5	Waste directed to disposal	Dana 2020 Sustainability & Social Responsibility Report: Planet / Environmental Stewardship and graphs detailing 2020 Hazardous Waste by Treatment Method (kg) and 2020 Non-Hazardous Waste by Treatment Method (kg)	SDG 12, 15
<b>GRI 307: Environmental Compliance</b>			
103-1	Explanation of the material topic and its boundary	Dana 2020 Sustainability & Social Responsibility Report: Appendix / Methodology	NA
103-2	The management approach and its components	Dana 2020 Sustainability & Social Responsibility Report: Planet / Environmental Stewardship	SDG 13, 14, 15, 16
103-3	Evaluation of the management approach	Dana 2020 Sustainability & Social Responsibility Report: Planet / Environmental Stewardship	SDG 13, 14, 15, 16
307-1	Non-compliance with environmental laws and regulations	No significant fines and/or non-monetary sanctions were levied against any of our sites in 2020. <a href="#">Dana 2020 10-K</a> , page 6	SDG 13, 14, 15, 16
<b>GRI 308: Supplier Environmental Assessment</b>			
103-1	Explanation of the material topic and its boundary	Dana 2020 Sustainability & Social Responsibility Report: Appendix / Methodology	NA
103-2	The management approach and its components	Dana 2020 Sustainability & Social Responsibility Report: Products / Sustainable Supply Chain	SDG 12, 16
103-3	Evaluation of the management approach	Dana 2020 Sustainability & Social Responsibility Report: Products / Sustainable Supply Chain	SDG 12, 16
308-1	New suppliers that were screened using the environmental criteria	Dana 2020 Sustainability & Social Responsibility Report: Products / Sustainable Supply Chain	SDG 12, 16
308-2	Negative environmental impacts in the supply chain and actions taken	Dana 2020 Sustainability & Social Responsibility Report: Products / Sustainable Supply Chain	SDG 12, 16

<b>GRI 401: Employment</b>			
103-1	Explanation of the material topic and its boundary	Dana 2020 Sustainability & Social Responsibility Report: Appendix / Methodology	NA
103-2	The management approach and its components	Dana 2020 Sustainability & Social Responsibility Report: People / People Development	SDG 8
103-3	Evaluation of the management approach	Dana 2020 Sustainability & Social Responsibility Report: People / People Development	SDG 8
401-1	New employee hires and employee turnover	Dana 2020 Sustainability & Social Responsibility Report: People / Employment Data	SDG 8
401-2	Benefits provided to full-time employees that are not provided to temporary or part-time employees	Dana 2020 Sustainability & Social Responsibility Report: People / Health and Well-Being <a href="#">Dana 2020 10-K</a> , pages 5 & 6 <a href="#">Careers Website</a>	SDG 3, 8
401-3	Parental leave	This information is being collected and analyzed.	SDG 3,8
<b>GRI 403: Occupational Health &amp; Safety</b>			
103-1	Explanation of the material topic and its boundary	Dana 2020 Sustainability & Social Responsibility Report: Appendix / Methodology	NA
103-2	The management approach and its components	Dana 2020 Sustainability & Social Responsibility Report: People / Safety First	SDG 3, 8
103-3	Evaluation of the management approach	Dana 2020 Sustainability & Social Responsibility Report: People / Safety First	SDG 3, 8
403-1	Occupational health and safety management system	Dana 2020 Sustainability & Social Responsibility Report: People / Safety First	SDG 3, 8
403-2	Hazard identification, risk assessment, and incident investigation	Dana 2020 Sustainability & Social Responsibility Report: People / Safety First The 81 sites certified to an OHS Management System are required to implement a robust hazard identification, risk assessment and incident investigation process as a requirement for 3 <sup>rd</sup> party certification.	SDG 3, 8
403-3	Occupational health services	Dana facilities maintain robust occupational health services while also protecting worker confidential information.	SDG 3, 8



403-4	Worker participation, consultation, and communication on occupational health and safety	Dana 2020 Sustainability & Social Responsibility Report: People / Safety First The 81 sites certified to an OHS Management System are required to implement a robust hazard identification, risk assessment and incident investigation process as a requirement for 3 <sup>rd</sup> party certification.	SDG 3, 8
403-5	Worker training on occupational health and safety	Dana 2020 Sustainability & Social Responsibility Report: People / Safety First The 81 sites certified to an OHS Management System are required to implement a robust hazard identification, risk assessment and incident investigation process as a requirement for 3 <sup>rd</sup> party certification.	SDG 3, 8
403-6	Promotion of worker health	Dana 2020 Sustainability & Social Responsibility Report: People / Safety First Dana 2020 Sustainability & Social Responsibility Report: People / Health and Well-Being	SDG 3, 8
403-7	Prevention and mitigation of occupational health and safety impacts	Dana 2020 Sustainability & Social Responsibility Report: People / Safety First The 81 sites certified to an OHS Management System are required to implement a robust hazard identification, risk assessment and incident investigation process as a requirement for 3 <sup>rd</sup> party certification.	SDG 3,8
403-8	Workers covered by an occupational health and safety management system	Dana 2020 Sustainability & Social Responsibility Report: People / Safety First	SDG 3, 8
403-9	Work-related injuries	Dana 2020 Sustainability & Social Responsibility Report: People / Safety and graphs detailing Lost Time Recordable and Recordable Incident Rates	SDG 3, 8
403-10	Work-related ill health	Dana 2020 Sustainability & Social Responsibility Report: People / Safety First and graphs detailing Lost Time Recordable and Recordable Incident Rates	SDG 3, 8
<b>GRI 404: Training &amp; Education</b>			
103-1	Explanation of the material topic and its boundary	Dana 2020 Sustainability & Social Responsibility Report: Appendix / Methodology	NA
103-2	The management approach and its components	Dana 2020 Sustainability & Social Responsibility Report: People / People Development	SDG 4, 8
103-3	Evaluation of the management approach	Dana 2020 Sustainability & Social Responsibility Report: People / People Development	SDG 4, 8
404-1	Average hours of training per year per employee	Dana 2020 Sustainability & Social Responsibility Report: People / Safety First Dana 2020 Sustainability & Social Responsibility Report: People / People Development	SDG 4, 8

404-2	Programs for upgrading employee skills and transition assistance programs	Dana 2020 Sustainability & Social Responsibility Report: People / People Development	SDG 4, 8
404-3	Percentage of employees receiving regular performance and career development reviews	Dana 2020 Sustainability & Social Responsibility Report: People / People Development	SDG 4, 8
<b>GRI 405: Diversity &amp; Equal Opportunity</b>			
103-1	Explanation of the material topic and its boundary	Dana 2020 Sustainability & Social Responsibility Report: Appendix / Methodology	NA
103-2	The management approach and its components	Dana 2020 Sustainability & Social Responsibility Report: People / Inclusion and Diversity	SDG 5, 8, 10
103-3	Evaluation of the management approach	Dana 2020 Sustainability & Social Responsibility Report: People / Inclusion and Diversity	SDG 5, 8, 10
405-1	Diversity of governance bodies and employees	Dana 2020 Sustainability & Social Responsibility Report: People / Inclusion and Diversity and Employment Data <a href="#">Board of Directors</a>	SDG 5, 8, 10
405-2	Ratio of basic salary and remuneration of women to men	This information is being collected and analyzed.	SDG 5, 8, 10
<b>GRI 406: Non-Discrimination</b>			
103-1	Explanation of the material topic and its boundary	Dana 2020 Sustainability & Social Responsibility Report: Appendix / Methodology	NA
103-2	The management approach and its components	Dana 2020 Sustainability & Social Responsibility Report: People / Inclusion and Diversity	SDG 5, 8, 10
103-3	Evaluation of the management approach	Dana 2020 Sustainability & Social Responsibility Report: People / Inclusion and Diversity	SDG 5, 8, 10
406-1	Incidents of discrimination and corrective actions taken	Dana 2020 Sustainability & Social Responsibility Report: Governance	SDG 5, 8, 10, 16



<b>GRI 414: Supplier Social Assessment</b>			
103-1	Explanation of the material topic and its boundary	Dana 2020 Sustainability & Social Responsibility Report: Appendix / Methodology	NA
103-2	The management approach and its components	Dana 2020 Sustainability & Social Responsibility Report: Products / Sustainable Supply Chain	SDG 12
103-3	Evaluation of the management approach	Dana 2020 Sustainability & Social Responsibility Report: Products / Sustainable Supply Chain	SDG 12
414-1	New suppliers that were screened using the social criteria	Dana 2020 Sustainability & Social Responsibility Report: Products / Sustainable Supply Chain	SDG 12
<b>Material Topic: Innovation and Product Lifecycle Management</b>			
103-1	Explanation of the material topic and its boundary	Dana 2020 Sustainability & Social Responsibility Report: Appendix / Methodology	NA
103-2	The management approach and its components	Dana 2020 Sustainability & Social Responsibility Report: Products / Electrification. Delivered.	SDG 8, 9, 13
103-3	Evaluation of the management approach	Dana 2020 Sustainability & Social Responsibility Report: Products / Electrification. Delivered.	SDG 8, 9, 13
Misc.	Innovation	Dana 2020 Sustainability & Social Responsibility Report: Products / Electrification. Delivered. <a href="#">Dana 2020 10-K</a> , page 4 (Engineering and Research and Development) <a href="#">Innovation and Technology</a> <a href="#">Markets</a> <a href="#">e-Mobility</a>	SDG 8, 9, 13
Misc.	Product Lifecycle Management	The information is being collected and will be reported at a later date.	SDG 8, 9, 13



# SASB Index

The Sustainability Accounting Standards Board (SASB) is an independent nonprofit organization that sets standards to guide the disclosure of financially material sustainability information by companies to their investors. SASB Standards identify the subset of environmental, social, and governance (ESG) issues most relevant to financial performance.

Disclosure Number	Disclosure Name	2020 Response	SDGs
<b>Energy Management</b>			
TR-AP 130a.1.1	Total energy Consumption in gigajoules (GJ)	6,523,888 GJ in 2020; 10.5% decrease from 2019	SDG 7, 12, 13
TR-AP 130a.1.2	Percentage of grid electricity consumed	99.6% in 2020; equivalent to 2019 consumption of grid electricity	SDG 7, 12, 13
TR-AP 103a.1.3	Percentage of renewable energy consumed	0.4% in 2020; Dana has installed solar panels at several facilities, entered into an agreement with the Toledo Community Foundation to purchase electricity from a newly constructed solar array, and has signed a long-term virtual power purchase agreement with NextEra Energy generating 300,000 MWh of renewable electricity annually beginning in 2022.  Dana 2020 Sustainability & Social Responsibility Report: Planet / Tackling Climate Change	SDG 7, 12, 13
<b>Waste Management</b>			
TR-AP 150a.1.1	Total amount of waste generated in metric tons (MT)	164,476 MT in 2020	SDG 12, 15
TR-AP 150a.1.2	Percentage of waste generated that was hazardous	5% in 2020	SDG 12, 15
TR-AP 150a.1.3	Percentage of waste generated that was recycled	71% in 2020	SDG 12, 15

<b>Product Safety</b>			
TR-AP 250a.1.1	Total number of recalls issued	Dana had one voluntary recall in 2020 that involved 1,001 vehicles.	SDG 9, 16
TR-AP 250.a.1.2	Total number of units that were subject to a recall	Zero involuntary recalls were issued to Dana in 2020.	SDG 9, 16
<b>Design for Fuel Efficiency</b>			
TR-AP 410a.1.1	Total revenue from products that are designed to increase fuel efficiency and/or reduce emissions during their use	This information is being collected and will be assessed and reported at a later date.	SDG 8, 9, 13
<b>Materials Sourcing</b>			
TR-AP 440a.1.1	Strategic approach to managing risks associated with the use of critical materials in products	Dana does not use any of the critical materials listed in the standard. Dana has a policy and process to manage identified Conflict Minerals. Dana 2020 Sustainability & Social Responsibility Report: Governance	SDG 9, 10, 12
TR-AP 440a.1.2	Identify the critical materials that present a significant risk to operations	Dana does not use any of the critical materials listed in the standard. Dana has a policy and process to manage identified Conflict Minerals. Dana 2020 Sustainability & Social Responsibility Report: Governance	SDG 9, 10, 12
TR-AP 440a.1.3	Disclosure sufficient for the risk without compromising confidential information	Dana does not use any of the critical materials listed in the standard. Dana has a policy and process to manage identified Conflict Minerals. Dana 2020 Sustainability & Social Responsibility Report: Governance	SDG 9, 10, 12



<b>Materials Efficiency</b>			
TR-AP 440b.1.1	Percentage of products sold, by revenue, that are recyclable	The information is being collected and will be reported at a later date.	SDG 9, 12
TR-AP 440b.1.2	Percentage calculated as the revenue from products sold that are recyclable divided by the revenue from all products sold		SDG 9, 12
TR-AP 440b.1.3	Limit to products that are automotive parts, components, and materials		SDG 9, 12
TR-AP 440b.2.1	Percentage of input materials that are derived from recycled or remanufactured content		SDG 9, 12
TR-AP 440b.2.2	Percentage calculated as the weight of input materials consumed derived from recycled or remanufactured content divided by the total weight of all input materials consumed		SDG 9, 12
<b>Competitive Behavior</b>			
TR-AP 520a.1.1	Total amount of monetary losses incurred during the reporting period as a result of legal proceedings associated with anti-competitive behavior regulations	Dana's public filings would identify any significant monetary losses.	SDG 9, 16
TR-AP 520a.1.2	Any adjudicative proceeding before a court, a regulator, an arbitrator, or otherwise	Dana's public filings would identify any significant pending proceedings.	SDG 9, 16





<p>TR-AP 520a.1.3</p>	<p>Losses, including any monetary liabilities to the opposing parties or others, fines and other monetary liabilities incurred during the reporting period as a result of civil actions, regulatory proceedings, and criminal actions</p>	<p>Dana’s public filings outline its financial status including recurring and non-recurring items. Any significant losses will be identified in this information.</p>	<p>SDG 9, 16</p>
<p>TR-AP 520a.1.4</p>	<p>Scope of monetary losses excluding legal and other fees and expenses incurred in its defense</p>	<p>Dana’s public filings outline its financial status including recurring and non-recurring items. Any significant losses will be identified in this information.</p>	<p>SDG 9, 16</p>
<p>TR-AP 520a.1.5</p>	<p>Scope of the disclosure, including legal proceedings associated with the enforcement of relevant regulations</p>	<p>Dana’s public filings outline its financial status including recurring and non-recurring items. Any significant losses will be identified in this information.</p>	<p>SDG 9, 16</p>
<p>TR-AP 520a.1.6</p>	<p>Scope of the disclosure, including legal proceedings associated with enforcement of relevant industry regulations promulgated by regional, national, state, and local regulatory authorities</p>	<p>Dana’s public filings outline its financial status including recurring and non-recurring items. Any significant losses will be identified in this information.</p>	<p>SDG 9, 16</p>



# TCFD Index

The Financial Stability Board established the Task Force on Climate-related Financial Disclosures (TCFD) to develop recommendations for more effective climate-related disclosures that could promote more informed investment, credit, and insurance underwriting decisions and, in turn, enable stakeholders to understand better the concentrations of carbon-related assets in the financial sector and the financial system’s exposures to climate-related risks.

Recommended Disclosure	2020 Response	SDGs
<b>Governance</b>		
<p><b>a.</b> Describe the Board’s oversight of climate-related risks and opportunities.</p>	<p>CDP Climate Change 2020 Report, Section C1.1</p> <p>C1.1: Board committees have expanded oversight to include environmental, social and governance (ESG) issues receiving sustainability updates on all ESG issues, including climate change. On July 28, 2020, Dana Incorporated announced that its Board of Directors has established a standing Technology and Sustainability Committee focused on technological and environmental stewardship. The Technology and Sustainability Committee is responsible for assisting the Board with oversight relating to innovation, new technologies, and sustainability and social responsibility. Key areas of focus for the Committee include the strategy, implementation, and effectiveness of Dana’s research and development initiatives, emerging trends in science, technology, and related regulations, strategic approach to technical talent management, and sustainability and social responsibility activities. More information can be found at: <a href="https://www.dana.com/newsroom/press-releases/dana-incorporated-board-of-directors-establishes-technology-and-sustainability-committee/">https://www.dana.com/newsroom/press-releases/dana-incorporated-board-of-directors-establishes-technology-and-sustainability-committee/</a></p>	<p>SDG 7, 12, 13</p>
<p><b>b.</b> Describe management’s role in assessing and managing climate-related risks and opportunities.</p>	<p>CDP Climate Change 2020 Report, Section C1.2</p> <p><a href="#">Sustainability &amp; Social Responsibility Governance</a></p>	<p>SDG 7, 12, 13</p>

<b>Strategy</b>		
<b>a.</b> Describe the climate-related risks and opportunities the organization has identified over the short, medium, and long term.	CDP Climate Change 2020 Report, Section C2.3, C2.4, C2.5 and C2.6	SDG 7, 12, 13
<b>b.</b> Describe the impact of climate-related risks and opportunities on the organization's businesses, strategy, and financial planning.	CDP Climate Change 2020 Report, Section C2.3, C2.4, C2.5 and C2.6	SDG 7, 12, 13
<b>c.</b> Describe the resilience of the organization's strategy, taking into consideration different climate-related scenarios, including 2°C or lower scenario.	This information will be included in the 2021 CDP submission.	SDG 7, 12, 13
<b>Risk Management</b>		
<b>a.</b> Describe the organization's processes for identifying and assessing climate-related risks.	CDP Climate Change 2020 Report, Section C2.2b	SDG 7, 12, 13
<b>b.</b> Describe the organization's processes for managing climate-related risks.	CDP Climate Change 2020 Report, Section C2.2d	SDG 7, 12, 13
<b>c.</b> Describe how processes for identifying, assessing, and managing climate-related risks are integrated into the organization's overall risk management.	CDP Climate Change 2020 Report, Section C2.2c	SDG 7, 12, 13



<b>Metrics and Targets</b>		
<b>a.</b> Disclose the metrics used by the organization to assess climate-related risks and opportunities in line with its strategy and risk management process.	CDP Climate Change 2020 Report, Section C4.1	SDG 7, 12, 13
<b>b.</b> Disclose Scope 1, Scope 2, and if appropriate, Scope 3 greenhouse gas (GHG) emissions, and the related risks.	Dana 2020 Sustainability & Social Responsibility Report: Planet / Tackling Climate Change and graphs detailing 2020 GHG Emissions by Scope (kg CO <sub>2</sub> -e) and 2020 Energy Consumption by Type (MWh)	SDG 7, 12, 13
<b>c.</b> Describe the targets used by the organization to manage climate-related risks and opportunities and performance against targets.	CDP Climate Change 2020 Report, Section C4.1	SDG 7, 12, 13
<b>Transportation Group Metrics</b>		
<b>a.</b> Revenues/savings from investments in low-carbon alternatives (e.g. R&D, equipment, products or services)	This information will be included in the 2021 CDP submission.	SDG 7, 12, 13



*People Finding A Better Way<sup>®</sup>*